

Grizzly **Industrial, Inc.**®

MODEL G0773 **12" X 27" COMBO LATHE/MILL** **OWNER'S MANUAL** *(For models manufactured since 12/14)*

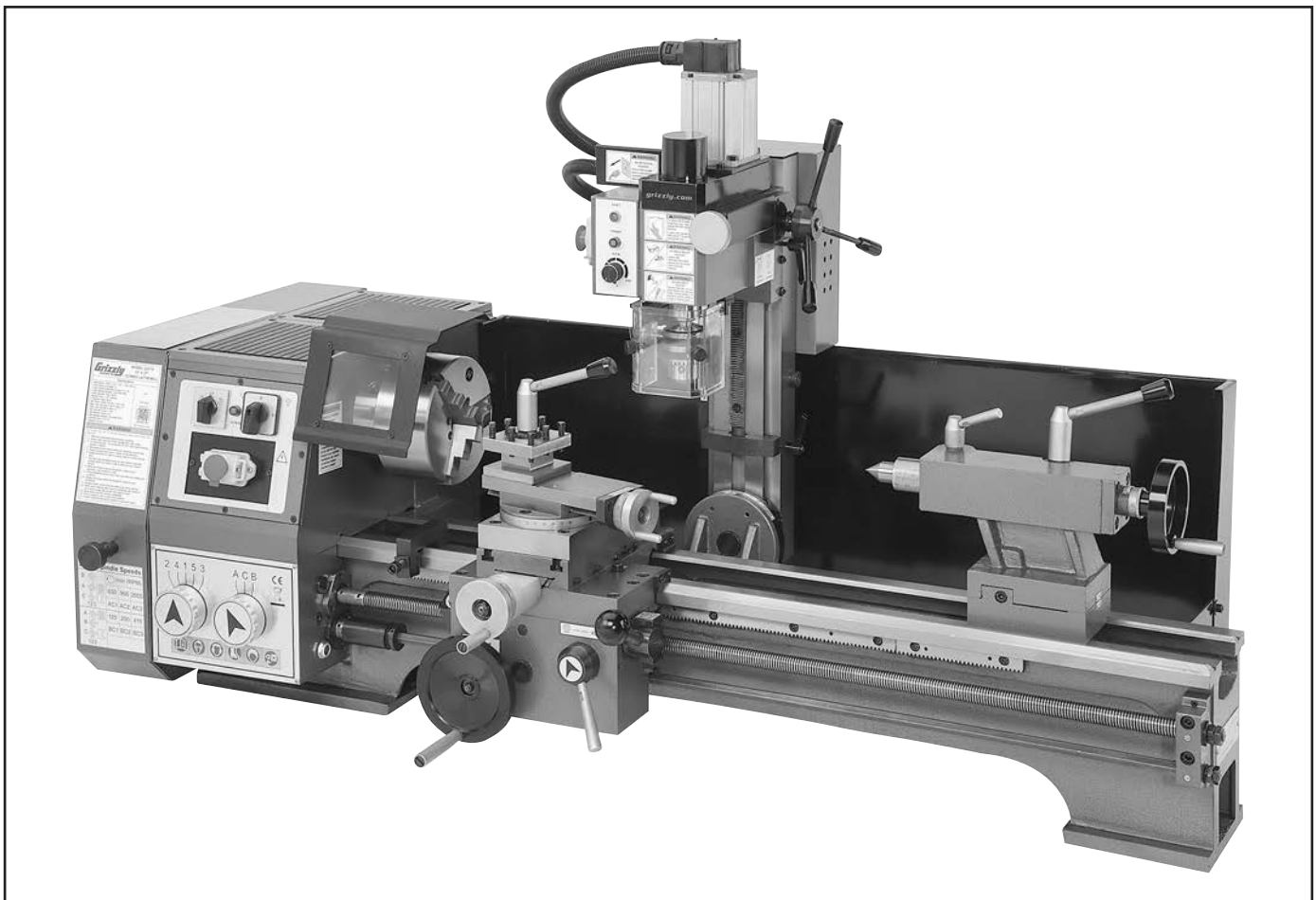

COPYRIGHT © MARCH, 2015 BY GRIZZLY INDUSTRIAL, INC.
**WARNING: NO PORTION OF THIS MANUAL MAY BE REPRODUCED IN ANY SHAPE
OR FORM WITHOUT THE WRITTEN APPROVAL OF GRIZZLY INDUSTRIAL, INC.**

WKBB17019 PRINTED IN CHINA

V1.03.15



WARNING!

This manual provides critical safety instructions on the proper setup, operation, maintenance, and service of this machine/tool. Save this document, refer to it often, and use it to instruct other operators.

Failure to read, understand and follow the instructions in this manual may result in fire or serious personal injury—including amputation, electrocution, or death.

The owner of this machine/tool is solely responsible for its safe use. This responsibility includes but is not limited to proper installation in a safe environment, personnel training and usage authorization, proper inspection and maintenance, manual availability and comprehension, application of safety devices, cutting/sanding/grinding tool integrity, and the usage of personal protective equipment.

The manufacturer will not be held liable for injury or property damage from negligence, improper training, machine modifications or misuse.



WARNING!

Some dust created by power sanding, sawing, grinding, drilling, and other construction activities contains chemicals known to the State of California to cause cancer, birth defects or other reproductive harm. Some examples of these chemicals are:

- **Lead from lead-based paints.**
- **Crystalline silica from bricks, cement and other masonry products.**
- **Arsenic and chromium from chemically-treated lumber.**

Your risk from these exposures varies, depending on how often you do this type of work. To reduce your exposure to these chemicals: Work in a well ventilated area, and work with approved safety equipment, such as those dust masks that are specially designed to filter out microscopic particles.

Table of Contents

INTRODUCTION	2	SECTION 5: MILL OPERATIONS	51
Machine Description	2	Operation Overview	51
Contact Info.....	2	Removing Compound Rest.....	52
Manual Accuracy	2	Headstock Movement	52
Identification.....	3	Table Travel.....	53
Controls & Components.....	4	Installing/Removing Tooling.....	54
G0773 Data Sheet.....	7	Spindle Speed.....	56
SECTION 1: SAFETY	10	SECTION 6: ACCESSORIES	57
Safety Instructions for Machinery	10	SECTION 7: MAINTENANCE	61
Additional Safety for Metal Lathes.....	12	Schedule	61
Additional Safety for Mills	13	Cleaning/Protecting.....	61
Additional Lathe Chuck Safety.....	14	Lubrication	62
SECTION 2: POWER SUPPLY	15	Machine Storage.....	66
SECTION 3: SETUP	17	SECTION 8: SERVICE	67
Setup Overview.....	17	Troubleshooting	67
Unpacking	17	Tensioning & Replacing V-Belts	70
Needed for Setup.....	17	Adjusting Backlash.....	71
Inventory	18	Adjusting Leadscrew End Play	71
Cleanup.....	19	Adjusting Gibs.....	72
Site Considerations.....	20	Adjusting Half Nut	73
Lifting & Placing	21	SECTION 8: WIRING	74
Mounting & Leveling	22	Wiring Safety Instructions	74
Assembly	23	Wiring Overview.....	75
Test Run	24	Wiring Diagram	76
Spindle Break-In	26	Wiring Photos.....	77
Recommended Adjustments.....	26	SECTION 10: PARTS	78
SECTION 4: LATHE OPERATIONS	27	Accessories.....	78
Operation Overview	27	Lathe Bed.....	79
Chuck Mounting	28	Tailstock.....	82
Installation & Removal Device.....	28	Tool Post.....	83
Chuck Installation.....	28	Cross Slide.....	84
Chuck Removal.....	30	Apron	86
Scroll Chuck Clamping	30	Apron Parts List	87
Changing Jaw Set.....	31	Gearbox	88
Tailstock.....	32	Change Gears.....	90
Dead Centers.....	36	Motor & Drive	92
Compound Rest.....	38	Mill.....	94
Four-Way Tool Post.....	38	Labels & Cosmetics	97
Manual Feed.....	40	SECTION 11: APPENDIX	98
Spindle Speed.....	41	Threading & Feeding Chart	98
Understanding Gear Charts.....	42	Thread Dial Chart	98
Power Feed.....	44	WARRANTY & RETURNS	101
End Gears.....	46		
Threading.....	49		

INTRODUCTION

Machine Description

The Model G0773 12" x 27" Combo Lathe/Mill features a lathe with 735 Watt (1 HP) 110V motor, 6-speed variable-speed controls, 6" 3-jaw chuck, a 4-way turret toolpost, and a full length splash guard.

The mill section features a 14½" swing, electronic variable speed control, fine and course spindle downfeed with adjustable depth stop, R8 taper, and a drilling capacity of ½" in cast-iron and steel.

Both section are equipped with emergency stops, chuck guards, and eye shields for safety.

Contact Info

We stand behind our machines. If you have any questions or need help, use the information below to contact us. Before contacting, please get the serial number and manufacture date of your machine. This will help us help you faster.

Grizzly Technical Support
1203 Lycoming Mall Circle
Muncy, PA 17756
Phone: (570) 546-9663
Email: techsupport@grizzly.com

We want your feedback on this manual. What did you like about it? Where could it be improved? Please take a few minutes to give us feedback.

Grizzly Documentation Manager
P.O. Box 2069
Bellingham, WA 98227-2069
Email: manuals@grizzly.com

Manual Accuracy

We are proud to provide a high-quality owner's manual with your new machine!

We made every effort to be exact with the instructions, specifications, drawings, and photographs contained inside. Sometimes we make mistakes, but our policy of continuous improvement also means that **sometimes the machine you receive will be slightly different than what is shown in the manual.**

If you find this to be the case, and the difference between the manual and machine leaves you confused about a procedure, check our website for an updated version. We post current manuals and manual updates for free on our website at www.grizzly.com.

Alternatively, you can call our Technical Support for help. Before calling, please write down the **Manufacture Date** and **Serial Number** stamped into the machine ID label (see below). This information helps us determine if updated documentation is available for your machine.

		MODEL GXXXX	
		MACHINE NAME	
SPECIFICATIONS		▲ WARNING!	
Motor:		To reduce risk of serious injury when using this machine:	
Specification:		Read manual before operation.	
Specification:		Wear safety glasses and respirator.	
Specification:		Adjustments must be precisely adjusted/setup and	
Weight:		power is connected to grounded circuit before starting.	
		4. Make sure the motor has stopped and disconnect	
		power before adjustments, maintenance, or service.	
		5. DO NOT expose to rain or dampness.	
		6. DO NOT modify this machine in any way.	
		7.	
		8.	
		9. Do not use while under the influence of drugs or alcohol.	
		10. Maintain machine carefully to prevent accidents.	

Manufactured for Grizzly in Taiwan

Manufacture Date

Serial Number



Identification

Study the names and locations of the controls and components shown below to familiarize yourself with the machine and better understand the terms used throughout this manual.

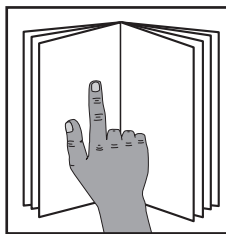
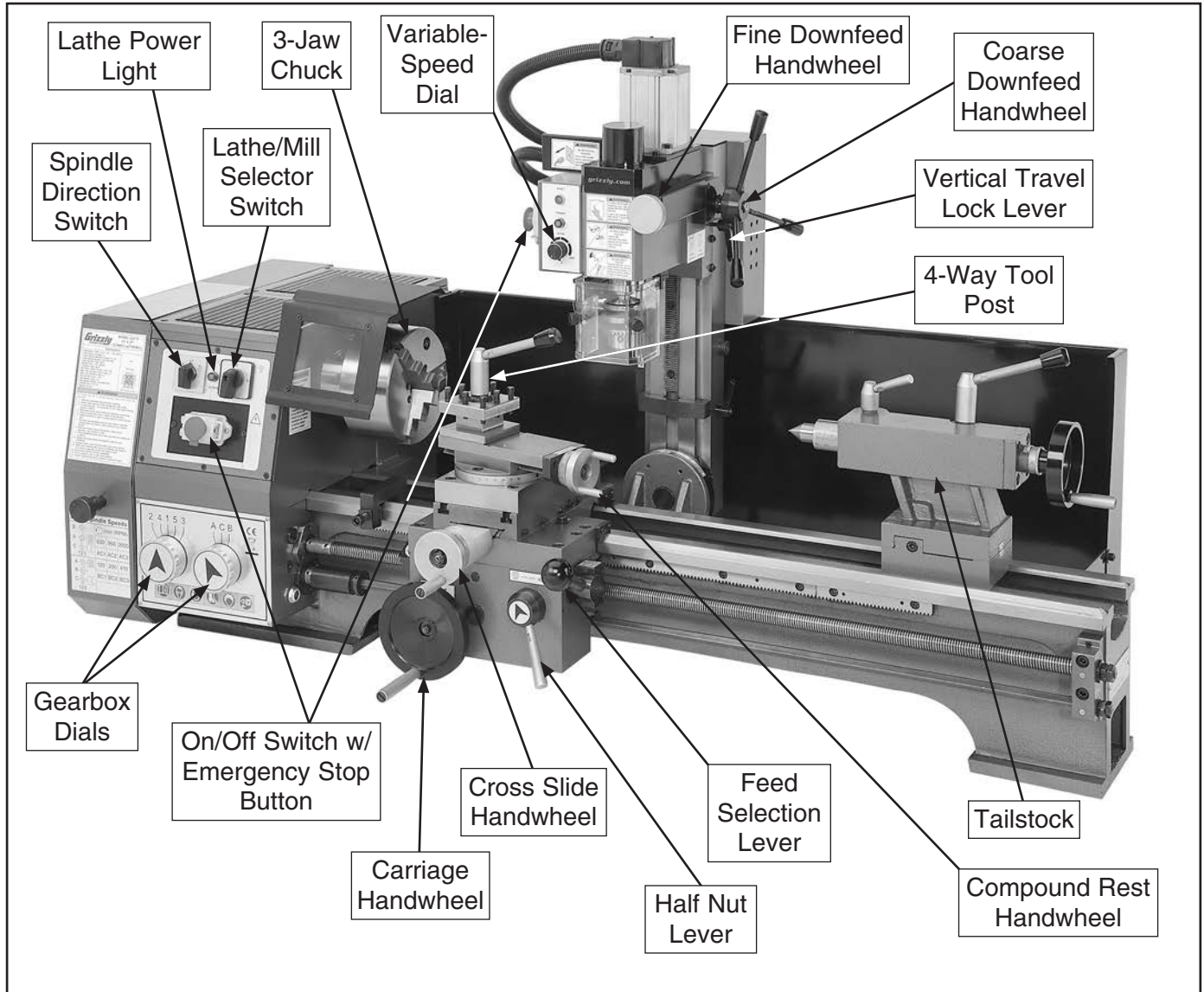

⚠️ WARNING

To reduce your risk of serious injury, read this entire manual **BEFORE** using machine.



Controls & Components

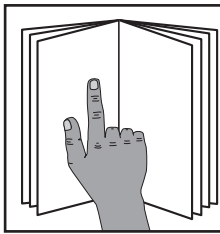

⚠️ WARNING

To reduce your risk of serious injury, read this entire manual BEFORE using machine.

Refer to **Figures 1–5** and the following descriptions to become familiar with the basic controls of this machine.

Headstock

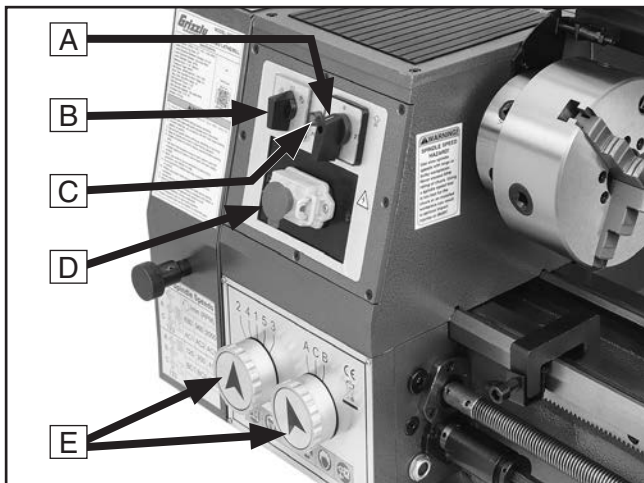

Figure 1. Headstock controls.

- A. Lathe/Mill Selector Switch:** Used to select between lathe mode (1) or mill mode (2).
- B. Spindle Direction Switch:** Selects spindle rotation direction.
- C. Lathe Power Indicator Light:** Illuminates when Lathe/Mill Selector Switch is set to lathe mode.
- D. ON/OFF Switch w/Emergency Stop Button:** When pressed, cuts power to motor and control panel. To reset, press front tab, lift switch cover, and press green ON button. Cover must be unlatched for machine to run.
- E. Gearbox Dials:** Control rate of carriage power feed, as indicated in threading and feeding charts.

Carriage

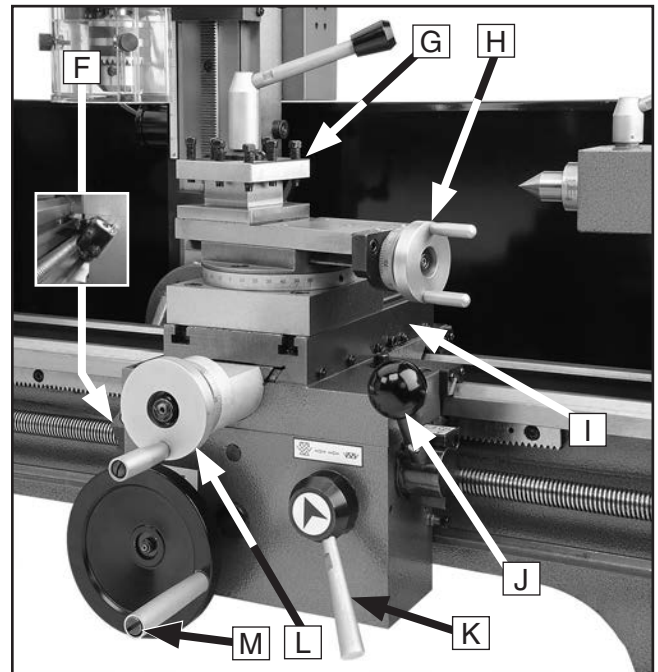

Figure 2. Carriage controls.

- F. Thread Dial:** Indicates when to engage half nut during threading operations.
- G. 4-Way Tool Post:** Holds up to four cutting tools at once that can be individually indexed to workpiece and quickly moved into position when needed.
- H. Compound Rest Handwheel:** Moves tool toward and away from workpiece at preset compound angle.
- I. Cross Slide Table:** Supports compound rest for lathe operations, and workpieces for milling operations. Includes (2) $\frac{3}{8}$ " T-slots spaced 3.55" (90mm) on center, for mounting milling vises or other fixtures.
- J. Feed Selection Lever:** Selects carriage or cross slide for power feed.
- K. Half Nut Lever:** Engages/disengages half nut for threading operations.
- L. Cross Slide Handwheel:** Moves cross slide toward and away from workpiece.
- M. Carriage Handwheel:** Manually moves carriage left or right along bedway.



Tailstock

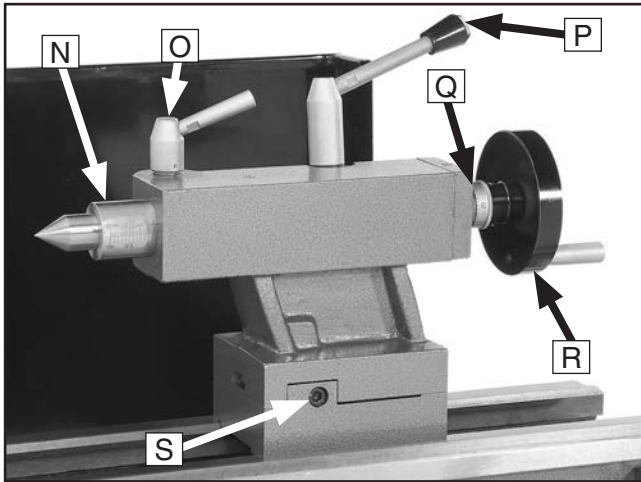

Figure 3. Tailstock controls.

- N. **Tailstock Quill:** Equipped with an MT#2 taper to hold centers or other tooling; features a scale on the side for use as a depth guide.
- O. **Tailstock Quill Lock Lever:** Secures quill position so it doesn't shift during operations.
- P. **Tailstock Lock Lever:** Secures tailstock position along bedway.
- Q. **Graduated Dial:** Indicates quill movement in increments of 0.001", with one full handwheel revolution equating 0.04" of quill travel.
- R. **Quill Handwheel:** Moves quill toward or away from spindle.
- S. **Tailstock Offset Screws:** Adjust tailstock offset left or right from spindle centerline (1 of 2).

End Gears, Pulleys, V-Belts

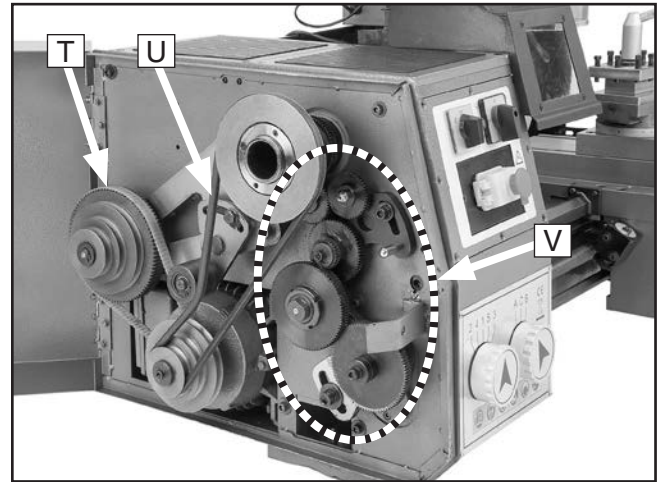

Figure 4. End gears, V-belts, and pulleys.

- T. **Timing Belt:** Used for controlling spindle speed, power feed speeds, and threading.
- U. **V-Belt:** Transfers power from motor to idler and spindle pulleys. The position of the V-belt on idler and spindle pulleys controls spindle speed.
- V. **End Gears:** The configuration of the end gears controls the leadscrew speed for power feeding, and inch and metric threading.

WARNING

Serious personal injury could occur if you connect the machine to power before completing the setup process. **DO NOT** connect power until instructed to do so later in this manual.



Milling Headstock

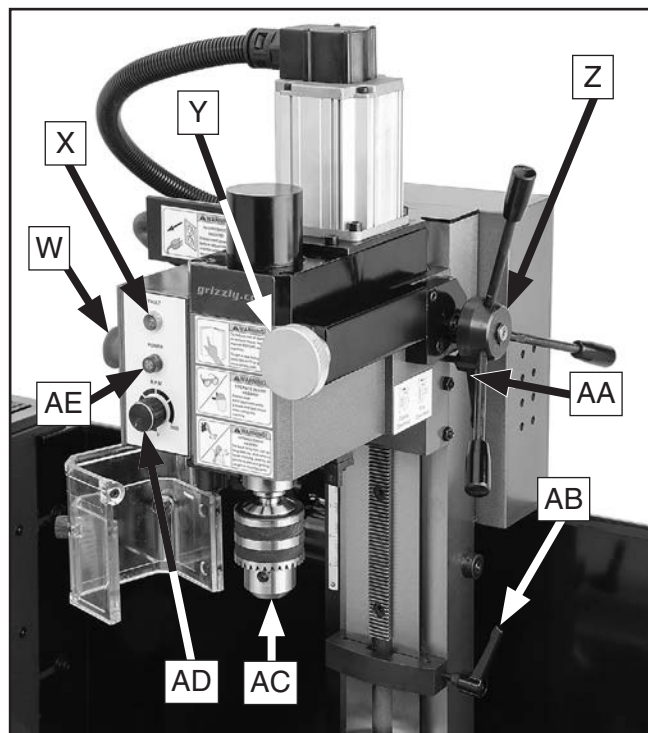

Figure 5. Milling headstock controls.

- W. ON/OFF Switch w/Emergency Stop Button:** When pressed, cuts power to motor and control panel. To reset, press front tab, lift switch cover, and press green ON button. Cover must be unlatched for machine to run.
- X. Mill Fault Light:** Illuminates if mill motor is overloaded.
- Y. Fine Vertical Handwheel:** Provides precision control of vertical headstock travel during setups.
- Z. Coarse Vertical Handwheel:** Raises and lowers headstock for Z-axis spindle positioning during setups.
- AA. Vertical Travel Lock Lever:** Locks headstock position along column.
- AB. Mill Depth Stop:** Limits downward movement of mill headstock.
- AC. Drill Chuck:** Holds drill bit during milling operations.
- AD. Variable-Speed Spindle Control Dial:** Provides variable control of spindle speed between 100–2500 RPM.
- AE. Mill Power Indicator Light:** Illuminates when Lathe/Mill Selector Switch (see **Page 4**) is set to milling mode.





MACHINE DATA SHEET

Customer Service #: (570) 546-9663 · To Order Call: (800) 523-4777 · Fax #: (800) 438-5901

MODEL G0773 12" X 27" COMBO LATHE/MILL

Product Dimensions:

Weight..... 546 lbs.
 Width (side-to-side) x Depth (front-to-back) x Height..... 59 x 30 x 33 in.
 Footprint (Length x Width)..... 59 x 30 in.

Shipping Dimensions:

Type..... Wood Crate
 Content..... Machine
 Weight..... 656 lbs.
 Length x Width x Height..... 61 x 27 x 38 in.
 Must Ship Upright..... Yes

Electrical:

Power Requirement..... 110V, Single-Phase, 60 Hz
 Full-Load Current Rating..... 11.6A
 Minimum Circuit Size..... 15A
 Connection Type..... Cord & Plug
 Power Cord Included..... Yes
 Power Cord Length..... 6 ft.
 Power Cord Gauge..... 16 AWG
 Plug Included..... Yes
 Included Plug Type..... NEMA 5-15
 Switch Type..... ON/OFF Push Button w/Safety Cover

Motors:

Mill Spindle

Type..... Brushless DC
 Horsepower..... 5/8 HP (500W)
 Phase..... Single-Phase
 Amps..... 2.8A
 Speed..... 5000 RPM
 Power Transfer Gear Drive
 Bearings..... Shielded & Permanently Sealed

Lathe Spindle

Type..... TEFC Capacitor-Start Induction
 Horsepower..... 1 HP (735W)
 Phase..... Single-Phase
 Amps..... 11.6A
 Speed..... 1700 RPM
 Power Transfer Belt Drive
 Bearings..... Shielded & Permanently Sealed



Main Specifications:

Lathe Info

Swing Over Bed.....	12 in.
Distance Between Centers.....	27-1/2 in.
Swing Over Cross Slide.....	7-3/8 in.
Swing Over Saddle.....	4-1/2 in.
Maximum Tool Bit Size.....	1/2 in.
Compound Travel.....	3 in.
Carriage Travel.....	23-5/8 in.
Cross Slide Travel.....	6 in.
Spindle Bore.....	1-1/2 in. (38mm)
Spindle Taper.....	MT#5
Number Of Spindle Speeds.....	6
Spindle Speeds.....	150, 240, 470, 720, 1130, 2100 RPM
Spindle Type.....	D1-4
Tailstock Quill Travel.....	3-1/8 in.
Tailstock Taper.....	MT#3
Number of Longitudinal Feeds.....	15
Range of Longitudinal Feeds.....	0.0016 – 0.015 in.
Number of Cross Feeds.....	15
Range of Cross Feeds.....	0.0008 – 0.0061 in.
Number of Inch Threads.....	21
Range of Inch Threads.....	5 – 72 TPI
Number of Metric Threads.....	12
Range of Metric Threads.....	0.5 – 4 mm

Mill Info

Mill Taper.....	R-8
Mill Spindle Travel.....	7-1/8 in.
Mill Swing.....	14-1/2 in.
Distance Spindle To Work Table.....	10 in.
Distance Spindle To Bed.....	12 in.
Distance Spindle To Center Line.....	6-1/2 in.
Mill Head Vertical Travel.....	7-1/16 in.
Maximum Tool Bit Size.....	5/8 in.
Drilling Capacity For Steel.....	1/2 in.
Drilling Capacity For Cast Iron.....	1/2 in.
Table Size Length.....	9-1/2 in.
Table Size Width.....	4-1/2 in.
Table Size Thickness.....	1-3/8 in.
Drawbar Diameter.....	7/16 in.
Drawbar TPI.....	20 TPI
Drawbar Length.....	6-3/4 in.
Number of Mill Drill Speeds.....	Variable
Mill Speed Range.....	100 – 2500 RPM

Construction

Bed.....	Induction-Hardened Cast Iron
Headstock.....	Cast Iron
Body.....	Cast Iron
End Gears.....	Steel
Paint Type/Finish.....	Epoxy

Other

Bed Width.....	6-1/8 in.
Carriage Leadscrew Diameter.....	3/4 in.
Carriage Leadscrew TPI.....	8 TPI
Carriage Leadscrew Length.....	42-1/16 in.
Cross Slide Leadscrew Diameter.....	9/16 in.
Cross Slide Leadscrew TPI.....	14 TPI
Cross Slide Leadscrew Length.....	13-1/2 in.



Other Specifications:

Country of Origin China
Warranty 1 Year
Approximate Assembly & Setup Time 1 Hour
Serial Number Location ID Label

Features:

Full-length splash guard
Emergency stop on lathe and mill
Headstock and mill eyeshields
Thread dial indicator
T-slots in cross slide
Handwheel dials graduated in inches
Electronic variable-speed control on mill
Fine and coarse mill spindle downfeed with adjustable depth stop
Column tilts 45 degrees left and right
Chuck guard with safety switch on lathe and mill

Accessories Included:

6" 3-jaw scroll chuck
4-way turret tool post
MT#3 and MT#5 dead centers
Bottle for oil

Accessories Recommended:

T10255 Mini Lathe Tool Kit
T25250 58 pc Clamping Kit 5/16"-18, 3/8" T-Slot
G1070 Live Center Set - Taper: MT3
H7661 Quick Vise
T10253 2" Mini Self Centering Vise with Swivel Base
T10254 2" Mini Self Centering Vise
H5931 4 pc. Center Drill Set 82°
H5930 4 pc. Center Drill Set 60°
T23962 Moly-D Machine and Way Oil - ISO 68, 5 Gallon
T23963 Moly-D Multi-Function Machine Oil-ISO 32, 5 Gallon
SB1365 Way Oil for Lathes
T23964 Armor Plate with Moly-D Multi-purpose Grease, 14.5 oz.
H7616 High Pressure Oil Can, 5 Oz. With Plastic Nozzle



SECTION 1: SAFETY

For Your Own Safety, Read Instruction Manual Before Operating This Machine

The purpose of safety symbols is to attract your attention to possible hazardous conditions. This manual uses a series of symbols and signal words intended to convey the level of importance of the safety messages. The progression of symbols is described below. Remember that safety messages by themselves do not eliminate danger and are not a substitute for proper accident prevention measures. Always use common sense and good judgment.

 **DANGER** Indicates an imminently hazardous situation which, if not avoided, **WILL** result in death or serious injury.

 **WARNING** Indicates a potentially hazardous situation which, if not avoided, **COULD** result in death or serious injury.

 **CAUTION** Indicates a potentially hazardous situation which, if not avoided, **MAY** result in minor or moderate injury. It may also be used to alert against unsafe practices.

NOTICE This symbol is used to alert the user to useful information about proper operation of the machine.

Safety Instructions for Machinery

WARNING

OWNER'S MANUAL. Read and understand this owner's manual **BEFORE** using machine.

TRAINED OPERATORS ONLY. Untrained operators have a higher risk of being hurt or killed. Only allow trained/supervised people to use this machine. When machine is not being used, disconnect power, remove switch keys, or lock-out machine to prevent unauthorized use—especially around children. Make workshop kid proof!

DANGEROUS ENVIRONMENTS. Do not use machinery in areas that are wet, cluttered, or have poor lighting. Operating machinery in these areas greatly increases the risk of accidents and injury.

MENTAL ALERTNESS REQUIRED. Full mental alertness is required for safe operation of machinery. Never operate under the influence of drugs or alcohol, when tired, or when distracted.

ELECTRICAL EQUIPMENT INJURY RISKS. You can be shocked, burned, or killed by touching live electrical components or improperly grounded machinery. To reduce this risk, only allow qualified service personnel to do electrical installation or repair work, and always disconnect power before accessing or exposing electrical equipment.

DISCONNECT POWER FIRST. Always disconnect machine from power supply **BEFORE** making adjustments, changing tooling, or servicing machine. This prevents an injury risk from unintended startup or contact with live electrical components.

EYE PROTECTION. Always wear ANSI-approved safety glasses or a face shield when operating or observing machinery to reduce the risk of eye injury or blindness from flying particles. Everyday eyeglasses are **NOT** approved safety glasses.



WARNING

WEARING PROPER APPAREL. Do not wear clothing, apparel or jewelry that can become entangled in moving parts. Always tie back or cover long hair. Wear non-slip footwear to avoid accidental slips, which could cause loss of workpiece control.

HAZARDOUS DUST. Dust created while using machinery may cause cancer, birth defects, or long-term respiratory damage. Be aware of dust hazards associated with each workpiece material, and always wear a NIOSH-approved respirator to reduce your risk.

HEARING PROTECTION. Always wear hearing protection when operating or observing loud machinery. Extended exposure to this noise without hearing protection can cause permanent hearing loss.

REMOVE ADJUSTING TOOLS. Tools left on machinery can become dangerous projectiles upon startup. Never leave chuck keys, wrenches, or any other tools on machine. Always verify removal before starting!

USE CORRECT TOOL FOR THE JOB. Only use this tool for its intended purpose—do not force it or an attachment to do a job for which it was not designed. Never make unapproved modifications—modifying tool or using it differently than intended may result in malfunction or mechanical failure that can lead to personal injury or death!

AWKWARD POSITIONS. Keep proper footing and balance at all times when operating machine. Do not overreach! Avoid awkward hand positions that make workpiece control difficult or increase the risk of accidental injury.

CHILDREN & BYSTANDERS. Keep children and bystanders at a safe distance from the work area. Stop using machine if they become a distraction.

GUARDS & COVERS. Guards and covers reduce accidental contact with moving parts or flying debris. Make sure they are properly installed, undamaged, and working correctly.

FORCING MACHINERY. Do not force machine. It will do the job safer and better at the rate for which it was designed.

NEVER STAND ON MACHINE. Serious injury may occur if machine is tipped or if the cutting tool is unintentionally contacted.

STABLE MACHINE. Unexpected movement during operation greatly increases risk of injury or loss of control. Before starting, verify machine is stable and mobile base (if used) is locked.

USE RECOMMENDED ACCESSORIES. Consult this owner's manual or the manufacturer for recommended accessories. Using improper accessories will increase the risk of serious injury.

UNATTENDED OPERATION. To reduce the risk of accidental injury, turn machine **OFF** and ensure all moving parts completely stop before walking away. Never leave machine running while unattended.

MAINTAIN WITH CARE. Follow all maintenance instructions and lubrication schedules to keep machine in good working condition. A machine that is improperly maintained could malfunction, leading to serious personal injury or death.

CHECK DAMAGED PARTS. Regularly inspect machine for any condition that may affect safe operation. Immediately repair or replace damaged or mis-adjusted parts before operating machine.

MAINTAIN POWER CORDS. When disconnecting cord-connected machines from power, grab and pull the plug—NOT the cord. Pulling the cord may damage the wires inside. Do not handle cord/plug with wet hands. Avoid cord damage by keeping it away from heated surfaces, high traffic areas, harsh chemicals, and wet/damp locations.

EXPERIENCING DIFFICULTIES. If at any time you experience difficulties performing the intended operation, stop using the machine! Contact our Technical Support at (570) 546-9663.



Additional Safety for Metal Lathes

WARNING

Serious injury or death can occur from getting entangled in, crushed between, or struck by rotating parts on a lathe! Unsecured tools or workpieces that fly loose from rotating objects can also strike nearby operators with deadly force. To minimize the risk of getting hurt or killed, anyone operating this machine **MUST** completely heed the hazards and warnings below.

CLOTHING, JEWELRY & LONG HAIR. Tie back long hair, remove jewelry, and do not wear loose clothing or gloves. These can easily get caught on rotating parts and pull you into lathe.

ROTATING PARTS. Always keep hands and body at a safe distance from rotating parts—especially those with projecting surfaces. Never hold anything against rotating workpiece, such as emery cloth, that can pull you into lathe.

GUARDING. Guards and covers protect against entanglement or flying objects. Always ensure they are properly installed while machine is running.

ADJUSTMENT TOOLS. Remove all chuck keys, wrenches, and adjustment tools before turning lathe **ON**. A tool left on the lathe can become a deadly projectile when spindle is started.

SAFE CLEARANCES. Before starting spindle, verify workpiece has adequate clearance by hand-rotating it through its entire range of motion.

NEW SETUPS. Test each new setup by starting spindle rotation at the lowest speed and standing to the side of the lathe until workpiece reaches full speed and you can verify safe rotation.

SPINDLE SPEEDS. Using spindle speeds that are too fast for the workpiece or clamping equipment can cause rotating parts to come loose and strike nearby people with deadly force. Always use slow spindle speeds with large or non-concentric workpieces. Never exceed rated RPM of the chuck.

LONG STOCK SAFETY. Long stock can whip violently if not properly supported. Always support any stock that extends from the chuck/headstock more than three times its own diameter.

CLEARING CHIPS. Metal chips can be razor sharp. Avoid clearing them by hand or with a rag. Use a brush or vacuum instead.

SECURE WORKPIECE. An improperly secured workpiece can fly off spindle with deadly force. Make sure workpiece is properly secured before starting the lathe.

CHUCKS. Chucks can be heavy and difficult to hold. During installation and removal, protect your hands and precision bed ways by using a chuck cradle or piece of plywood over the bed ways. Use lifting equipment, as necessary, for large chucks.

STOPPING SPINDLE. Always allow spindle to completely stop on its own, or use a brake, if provided. Never put hands or another object on a spinning workpiece to make it stop faster.

CRASHING. A serious explosion of metal parts can occur if cutting tool or other lathe component hits rotating chuck or a projecting part of workpiece. Resulting metal fragments can strike nearby people and lathe will be seriously damaged. To reduce risk of crashing, **ALWAYS** release automatic feeds after use, **NEVER** leave lathe unattended, and **CHECK** all clearances before starting lathe.

COOLANT SAFETY. Coolant can become very toxic through prolonged use and aging. To minimize toxicity, change coolant regularly. When using, position nozzle properly to avoid splashing operator or causing a slipping hazard on floor.

TOOL SELECTION. Cutting with incorrect or dull tooling increases risk of injury from broken or dislodged components, or as a result of extra force required for operation. Always use sharp tooling that is right for the job.

SANDING/POLISHING. To reduce risk of entanglement, never wrap emery cloth around rotating workpiece. Instead, use emery cloth with the aid of a tool or backing board.

MEASURING WORKPIECE. To reduce risk of entanglement, never measure rotating workpieces.



Additional Safety for Mills

WARNING

The primary risks of operating a Mill are as follows: You can be seriously injured or killed by getting clothing, jewelry, or long hair entangled with rotating cutter. You can be severely cut or have fingers amputated from contact with the rotating cutter. You can be blinded or struck by broken cutting tools, metal chips, workpieces, or adjustment tools thrown from the rotating spindle with great force. To reduce your risk of serious injury when operating this machine, completely heed and understand the following:

UNDERSTAND ALL CONTROLS. Make sure you understand the function and proper use of all controls before starting. This will help you avoid making mistakes that result in serious injury.

WEAR FACE SHIELD. Always wear a face shield in addition to safety glasses. This provides more complete protection for your face than safety glasses alone.

REMOVE CHUCK KEY & SPINDLE TOOLS. Always remove chuck key, drawbar wrench, and other tools used on the spindle immediately after use. This will prevent them from being thrown by the spindle upon startup.

PROPERLY SECURE CUTTER. Firmly secure cutting tool or drill bit so it does not fly out of spindle during operation.

USE CORRECT SPINDLE SPEED. Follow recommended speeds and feeds for each size and type of cutting tool. This helps avoid tool breakage during operation and ensures best cutting results.

INSPECT CUTTING TOOL. Inspect cutting tools for sharpness, chips, or cracks before each use. Replace dull, chipped, or cracked cutting tools immediately.

ALLOW SPINDLE TO STOP. To minimize your risk of entanglement, always allow spindle to stop on its own. DO NOT stop spindle using your hand or any other object.

SECURE WORKPIECE TO TABLE. Clamp workpiece to table or secure in a vise mounted to table, so workpiece cannot unexpectedly shift or spin during operation. NEVER hold workpiece by hand during operation.

CLEAN MACHINE SAFELY. Metal chips or shavings can be razor sharp. DO NOT clear chips by hand or compressed air that can force chips farther into machine—use a brush or vacuum instead. Never clear chips while spindle is turning.

PROPERLY MAINTAIN MACHINE. Keep machine in proper working condition to help ensure that it functions safely and all guards and other components work as intended. Perform routine inspections and all necessary maintenance. Never operate machine with damaged or worn parts that can break or result in unexpected movement during operation.

DISCONNECT POWER FIRST. To reduce risk of electrocution or injury from unexpected startup, make sure mill/drill is turned **OFF**, disconnected from power, and all moving parts have come to a complete stop before changing cutting tools or starting any inspection, adjustment, or maintenance procedure.

POWER DISRUPTION. In the event of a local power outage during operation, turn spindle switch **OFF** to avoid a possible sudden startup once power is restored.



Additional Lathe Chuck Safety

WARNING

ENTANGLEMENT. Entanglement with a rotating chuck can lead to death, amputation, broken bones, or other serious injury. Never attempt to slow or stop the lathe chuck by hand, and always roll up long sleeves, tie back long hair, and remove any jewelry or loose apparel BEFORE operating.

CHUCK SPEED RATING. Excessive spindle speeds greatly increase the risk of the workpiece or chuck being thrown from the machine with deadly force. Never use spindle speeds faster than the chuck RPM rating or the safe limits of your workpiece.

USING CORRECT EQUIPMENT. Many workpieces can only be safely turned in a lathe if additional support equipment, such as a tailstock or steady/follow rest, is used. If the operation is too hazardous to be completed with the lathe or existing equipment, the operator must have enough experience to know when to use a different machine or find a safer way.

TRAINED OPERATORS ONLY. Using a chuck incorrectly can result in workpieces coming loose at high speeds and striking the operator or bystanders with deadly force. To reduce the risk of this hazard, read and understand this document and seek additional training from an experienced chuck user before using a chuck.

CHUCK CAPACITY. Avoid exceeding the capacity of the chuck by clamping an oversized workpiece. If the workpiece is too large to safely clamp with the chuck, use a faceplate or a larger chuck if possible. Otherwise, the workpiece could be thrown from the lathe during operation, resulting in serious impact injury or death.

CLAMPING FORCE. Inadequate clamping force can lead to the workpiece being thrown from the chuck and striking the operator or bystanders. Maximum clamping force is achieved when the chuck is properly maintained and lubricated, all jaws are fully engaged with the workpiece, and the maximum chuck clamping diameter is not exceeded.

PROPER MAINTENANCE. All chucks must be properly maintained and lubricated to achieve maximum clamping force and withstand the rigors of centrifugal force. To reduce the risk of a thrown workpiece, follow all maintenance intervals and instructions in this document.

DISCONNECT POWER. Serious entanglement or impact injuries could occur if the lathe is started while you are adjusting, servicing, or installing the chuck. Always disconnect the lathe from power before performing these procedures.



SECTION 2: POWER SUPPLY

Availability

Before installing the machine, consider the availability and proximity of the required power supply circuit. If an existing circuit does not meet the requirements for this machine, a new circuit must be installed. To minimize the risk of electrocution, fire, or equipment damage, installation work and electrical wiring must be done by an electrician or qualified service personnel in accordance with all applicable codes and standards.

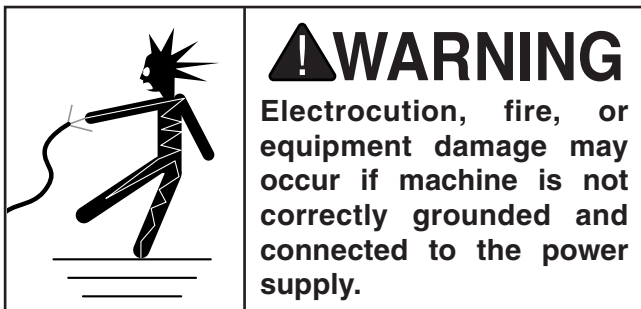

Full-Load Current Rating

The full-load current rating is the amperage a machine draws at 100% of the rated output power. On machines with multiple motors, this is the amperage drawn by the largest motor or sum of all motors and electrical devices that might operate at one time during normal operations.

Full-Load Rating 11.6A

The full-load current is not the maximum amount of amps that the machine will draw. If the machine is overloaded, it will draw additional amps beyond the full-load rating.

If the machine is overloaded for a sufficient length of time, damage, overheating, or fire may result—especially if connected to an undersized circuit. To reduce the risk of these hazards, avoid overloading the machine during operation and make sure it is connected to a power supply circuit that meets the specified circuit requirements.

! WARNING

Serious injury could occur if you connect the machine to power before completing the setup process. DO NOT connect to power until instructed later in this manual.

110V Circuit Requirements

This machine is prewired to operate on a power supply circuit that has a verified ground and meets the following requirements:

Nominal Voltage 110V, 115V, 120V
Cycle 60 Hz
Phase Single-Phase
Power Supply Circuit 15 Amps

A power supply circuit includes all electrical equipment between the breaker box or fuse panel in the building and the machine. The power supply circuit used for this machine must be sized to safely handle the full-load current drawn from the machine for an extended period of time. (If this machine is connected to a circuit protected by fuses, use a time delay fuse marked D.)

! CAUTION

For your own safety and protection of property, consult an electrician if you are unsure about wiring practices or electrical codes in your area.

Note: *Circuit requirements in this manual apply to a dedicated circuit—where only one machine will be running on the circuit at a time. If machine will be connected to a shared circuit where multiple machines may be running at the same time, consult an electrician or qualified service personnel to ensure circuit is properly sized for safe operation.*



Grounding & Plug Requirements

This machine **MUST** be grounded. In the event of certain malfunctions or breakdowns, grounding reduces the risk of electric shock by providing a path of least resistance for electric current.

This machine is equipped with a power cord that has an equipment-grounding wire and a grounding plug. Only insert plug into a matching receptacle (outlet) that is properly installed and grounded in accordance with all local codes and ordinances. **DO NOT** modify the provided plug!

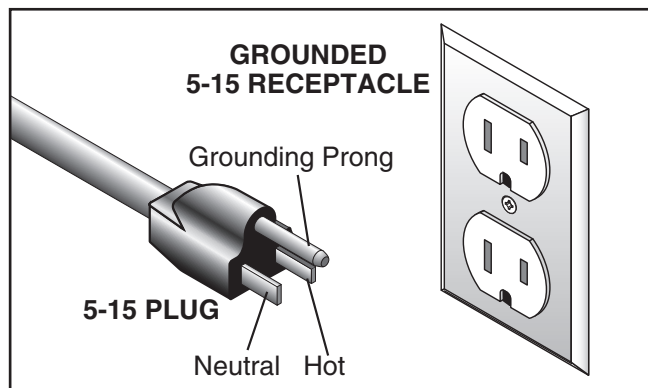

Figure 6. Typical 5-15 plug and receptacle.

⚠ CAUTION

SHOCK HAZARD!

Two-prong outlets do not meet the grounding requirements for this machine. Do not modify or use an adapter on the plug provided—if it will not fit the outlet, have a qualified electrician install the proper outlet with a verified ground.

Improper connection of the equipment-grounding wire can result in a risk of electric shock. The wire with green insulation (with or without yellow stripes) is the equipment-grounding wire. If repair or replacement of the power cord or plug is necessary, do not connect the equipment-grounding wire to a live (current carrying) terminal.

Check with a qualified electrician or service personnel if you do not understand these grounding requirements, or if you are in doubt about whether the tool is properly grounded. If you ever notice that a cord or plug is damaged or worn, disconnect it from power, and immediately replace it with a new one.

Extension Cords

We do not recommend using an extension cord with this machine. If you must use an extension cord, only use it if absolutely necessary and only on a temporary basis.

Extension cords cause voltage drop, which can damage electrical components and shorten motor life. Voltage drop increases as the extension cord size gets longer and the gauge size gets smaller (higher gauge numbers indicate smaller sizes).

Any extension cord used with this machine must be in good condition and contain a ground wire and matching plug/receptacle. Additionally, it must meet the following size requirements:

- Minimum Gauge Size 14 AWG**
- Maximum Length (Shorter is Better).....50 ft.**



SECTION 3: SETUP

Setup Overview

The list below outlines the basic process of setting up the machine for first-time operation. Specific steps are covered later in this section.

The typical setup process is as follows:

1. Unpack machine and inventory contents of box/crate.
2. Clean machine and its components.
3. Move machine to an acceptable location, level bedways, and secure in place.
4. Assemble machine and make sure it is ready for operation.
5. Connect machine to power source.
6. Test run machine and various safety components to ensure they function properly.
7. Perform spindle break-in procedure to prepare spindle bearings for operational loads.

Unpacking

Your machine was carefully packaged for safe transportation. Remove the packaging materials from around your machine and inspect it. If you discover any damage, *please call us immediately at (570) 546-9663 for advice.*

Save the containers and all packing materials for possible inspection by the carrier or its agent. *Otherwise, filing a freight claim can be difficult.*

When you are completely satisfied with the condition of your shipment, inventory the contents.



Needed for Setup

The following are needed to complete the setup process, but are not included with your machine.

Description

- Another Person for Moving Machine
- Safety Glasses
- Cleaner/Degreaser (**Page 19**)
- Quality Metal Protectant
- Disposable Shop Rags
- Forklift
- Lifting Slings (rated for at least 700 lbs.)
- Mounting Hardware (**Page 22**)



Inventory

The following is a list of items shipped with your machine. Before beginning setup, lay these items out and inventory them.

If any non-proprietary parts are missing (e.g. a nut or a washer), we will gladly replace them; or for the sake of expediency, replacements can be obtained at your local hardware store.

Installed Components (Figure 7)	Qty.
A. Lathe Chuck Guard	1
B. 3-Jaw Chuck	1
C. 4-Way Tool Post	1
D. Milling Headstock	1
E. Mill Safety Shield	1
F. Backsplash	1
G. Tailstock	1
H. Drill Chuck 1/2"	1

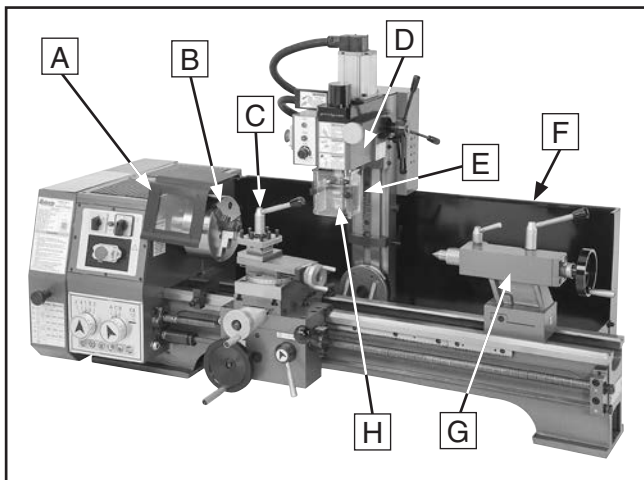

Figure 7. Components installed when shipped.

Loose Components (Figure 8)	Qty.
I. Open-End Wrench Set (8/10, 12/14, 17/19, 36mm)	1 Ea.
J. Dead Center MT#5	1
K. Dead Center MT#3	1
L. Lathe Chuck Key	1
M. Square Socket T-Wrench	1
N. Spanner Wrench 63mm Pin-Type	1
O. Spanner Wrench 45–52mm Hook-Type	1
P. Hardware Bag	1
—Cap Screw M10-1.5 x 35	4
—Cap Screw M10-1.5 x 30	3
—Cap Screw M8-1.25 x 25	4
—Flat Washer 10mm	7
—Lock Washer 10mm	3
Q. Spindle Locking Pin	1
R. Handwheel Handle (Cross Slide)	1
S. Handwheel Handle (Carriage)	1
T. Timing Belt	1
U. V-Belt	1
V. Mill Chuck Key 5/16" AH 11T SD-5/8"	1
W. Hex Wrench Set (3, 4, 5, 6, 8mm)	1 Ea.
X. Change Gear Set (35, 50, 60T)	1 Ea.
Y. 3-Jaw Chuck External Jaw Set	1

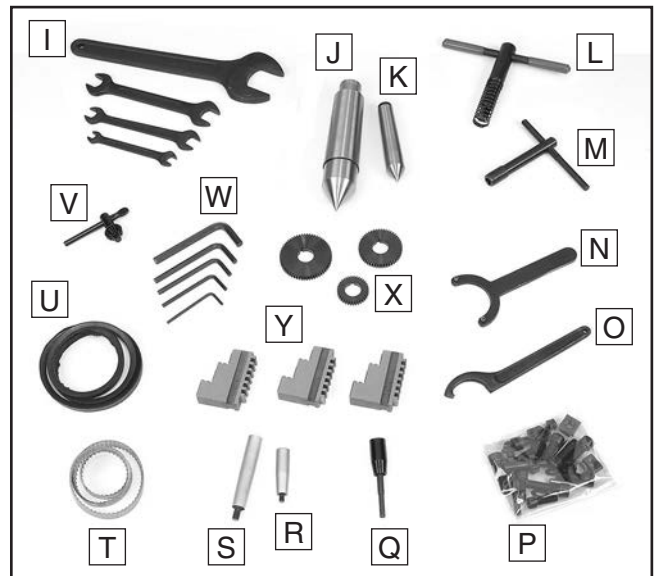

Figure 8. Components loose when shipped.

NOTICE

If you cannot find an item on this list, carefully check around/inside the machine and packaging materials. Often, these items get lost in packaging materials while unpacking or they are pre-installed at the factory.



Cleanup

The unpainted surfaces of your machine are coated with a heavy-duty rust preventative that prevents corrosion during shipment and storage. This rust preventative works extremely well, but it will take a little time to clean.

Be patient and do a thorough job cleaning your machine. The time you spend doing this now will give you a better appreciation for the proper care of your machine's unpainted surfaces.

There are many ways to remove this rust preventative, but the following steps work well in a wide variety of situations. Always follow the manufacturer's instructions with any cleaning product you use and make sure you work in a well-ventilated area to minimize exposure to toxic fumes.

Before cleaning, gather the following:

- Disposable rags
- Cleaner/degreaser (WD-40 works well)
- Safety glasses & disposable gloves
- Plastic paint scraper (optional)

Basic steps for removing rust preventative:

1. Put on safety glasses.
2. Coat the rust preventative with a liberal amount of cleaner/degreaser, then let it soak for 5–10 minutes.
3. Wipe off the surfaces. If your cleaner/degreaser is effective, the rust preventative will wipe off easily. If you have a plastic paint scraper, scrape off as much as you can first, then wipe off the rest with the rag.
4. Repeat **Steps 2–3** as necessary until clean, then coat all unpainted surfaces with a quality metal protectant to prevent rust.

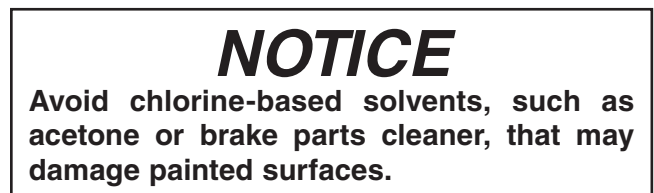
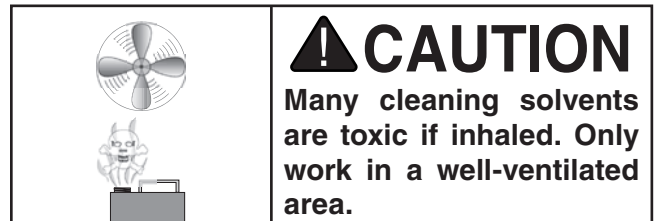
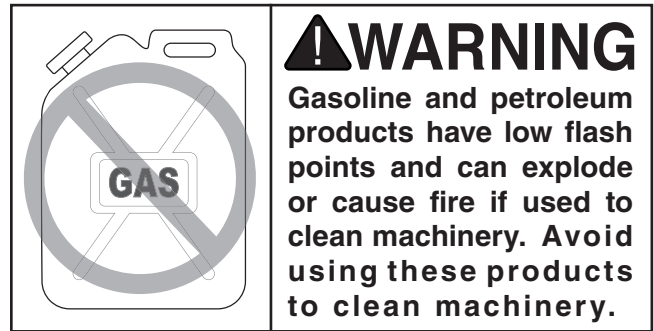

T23692—Orange Power Degreaser

A great product for removing the waxy shipping grease from your machine during clean up.



Figure 9. T23692 Orange Power Degreaser.



Site Considerations

Weight Load

Refer to the **Machine Data Sheet** for the weight of your machine. Make sure that the surface upon which the machine is placed will bear the weight of the machine, additional equipment that may be installed on the machine, and the heaviest workpiece that will be used. Additionally, consider the weight of the operator and any dynamic loading that may occur when operating the machine.

Space Allocation

Consider the largest size of workpiece that will be processed through this machine and provide enough space around the machine for adequate operator material handling or the installation of auxiliary equipment. With permanent installations, leave enough space around the machine to open or remove doors/covers as required by the maintenance and service described in this manual. **See below for required space allocation.**

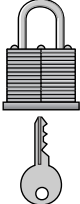
	<p>CAUTION Children or untrained people may be seriously injured by this machine. Only install in an access restricted location.</p>
---	---

Physical Environment

The physical environment where the machine is operated is important for safe operation and longevity of machine components. For best results, operate this machine in a dry environment that is free from excessive moisture, hazardous chemicals, airborne abrasives, or extreme conditions. Extreme conditions for this type of machinery are generally those where the ambient temperature range exceeds 41°–104°F; the relative humidity range exceeds 20%–95% (non-condensing); or the environment is subject to vibration, shocks, or bumps.

Electrical Installation

Place this machine near an existing power source. Make sure all power cords are protected from traffic, material handling, moisture, chemicals, or other hazards. Make sure to leave enough space around machine to disconnect power supply or apply a lockout/tagout device, if required.

Lighting

Lighting around the machine must be adequate enough that operations can be performed safely. Shadows, glare, or strobe effects that may distract or impede the operator must be eliminated.

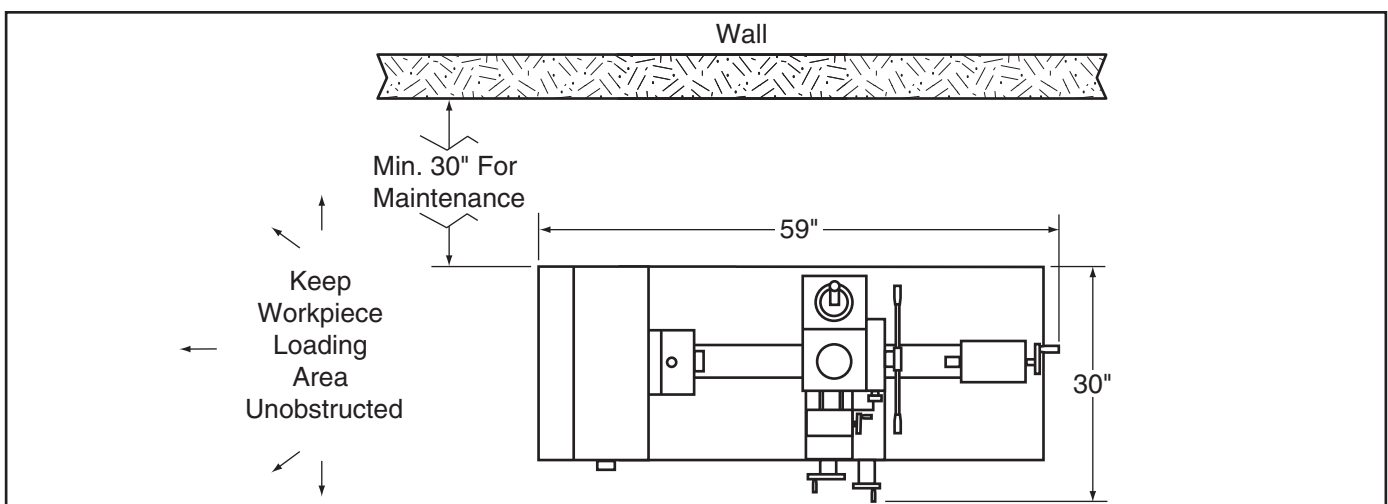
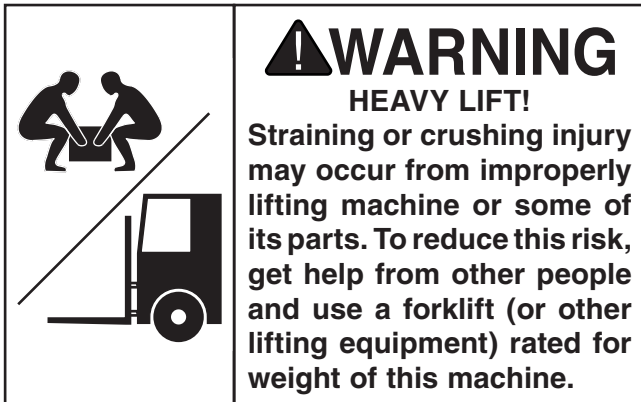

Figure 10. Minimum working clearances.



Lifting & Placing



Do not attempt to lift or move the machine without using the proper lifting equipment (such as a forklift or crane) or the necessary assistance from other people. Refer to **Needed for Setup on Page 17** for details.

To lift and place machine:

1. Remove shipping crate top and sides, then remove chip pan, 4-jaw chuck, faceplate, and toolbox from shipping pallet.
2. Position chip pan on workbench or other selected mounting surface to use it for marking hole locations for mounting hardware (refer to **Mounting on Page 22**).
3. Unbolt machine from shipping pallet.



4. To balance load for lifting, move tailstock and carriage to right end of bedway, then lock them in place.

Note: Before trying to move carriage, make sure carriage lock is loose and half nut is disengaged.

5. Wrap lifting slings around bed and between leadscrew and bedway, as shown in **Figure 11**, to help prevent bending leadscrew during lifting.

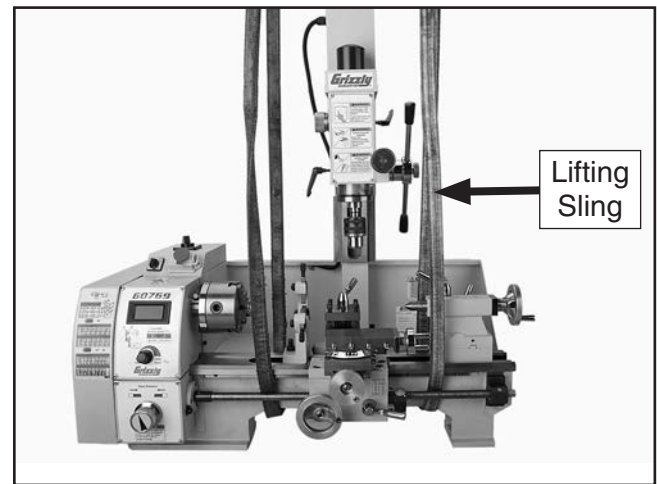
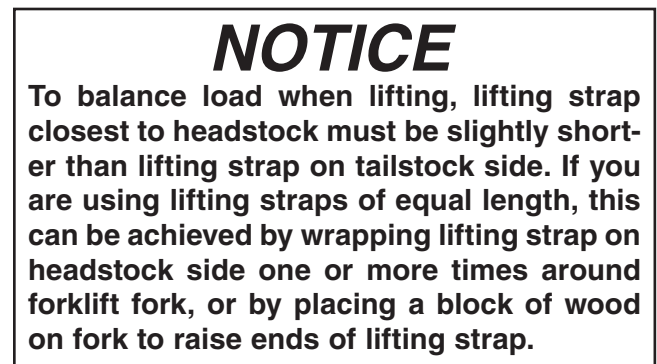

Figure 11. Example of lifting slings positioned correctly on a similar machine.

6. Attach lifting slings to forklift forks (or other power lifting equipment).



7. Have an assistant hold mill headstock to steady load, then lift machine just enough to clear any obstacles and move it to the workbench or other selected mounting location.
8. Properly secure machine in place as instructed in **Mounting** subsection on **Page 22**.



Mounting & Leveling

Number of Mounting Holes 4
 Diameter of Mounting Hardware..... 1/2"

Follow these guidelines when mounting your machine to ensure safe and accurate cutting results:

- Make sure stand or workbench can adequately support weight of machine and materials, and that it will not move or vibrate during operation.
- Use a silicon sealant between the machine base and chip pan to prevent coolant or other fluids from leaking through onto the stand, workbench, or floor.
 - If mounting machine to a stand (not included), follow the instructions included with it. Ensure stand is anchored to floor.
 - If mounting machine to a workbench, drill holes all the way through workbench, and use hex bolts, washers, and hex nuts to secure machine in place (see example below).

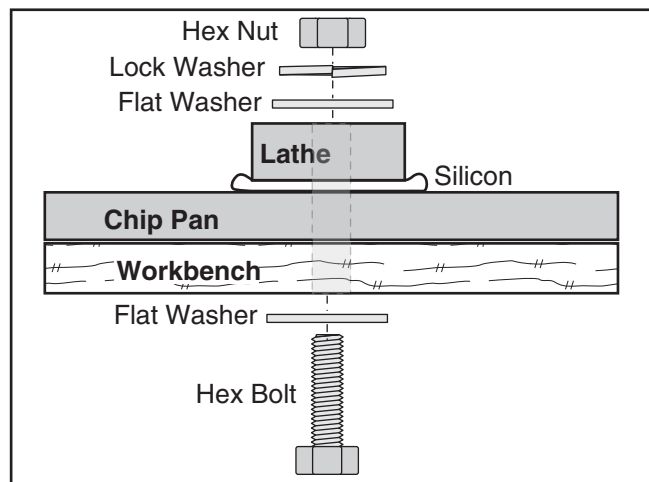

Figure 12. Example of a "Through Mount" setup.

NOTICE

For accurate turning results and to prevent warping the cast iron bed and ways, the lathe bedways **MUST** be leveled from side-to-side and from front-to-back on both ends.

Recheck the bedways 24 hours after installation, two weeks after that, and then annually to make sure they remain level.

Leveling machinery helps precision components, such as bedways, remain straight and flat during the lifespan of the machine. The bed on a lathe that is not level may slowly twist due to the dynamic loads placed on the machine during operation.

For best results, use a precision level that is at least 12" long and sensitive enough to show a distinct movement when a 0.003" shim (approximately the thickness of one sheet of standard newspaper) is placed under one end of the level.

See **Figure 13** for an example of a high-precision level.

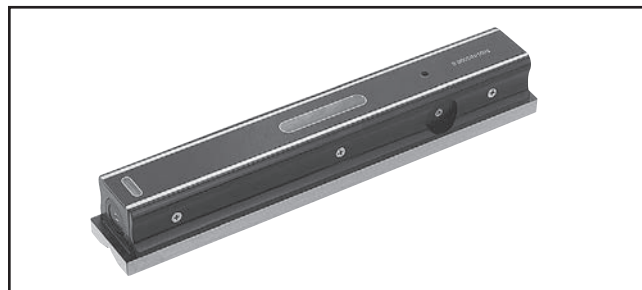

Figure 13. Grizzly Model H2683 12" Master Machinist's Level.



Assembly

With the exception of the handwheel handles and belts, the Model G0773 is shipped fully assembled.

To assemble machine:

1. Use a flat head screwdriver to attach handwheel handles shown in **Figure 14**.

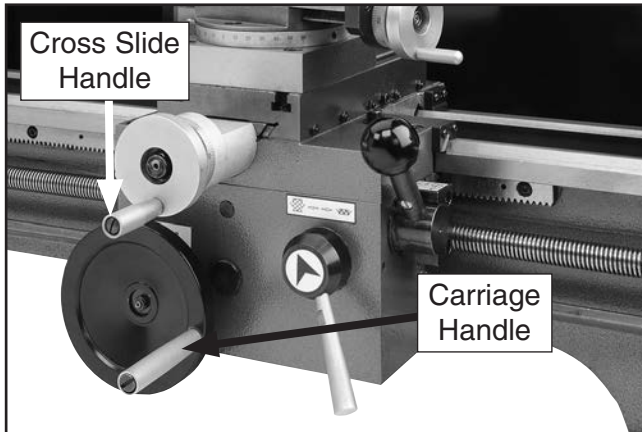

Figure 14. Handwheel handles installed.

2. Loosen (2) M12-1.75 hex nuts that secure timing-belt pulley to idler bracket (see **Figure 15**), allowing timing-belt pulley to slide in its mounting slot.

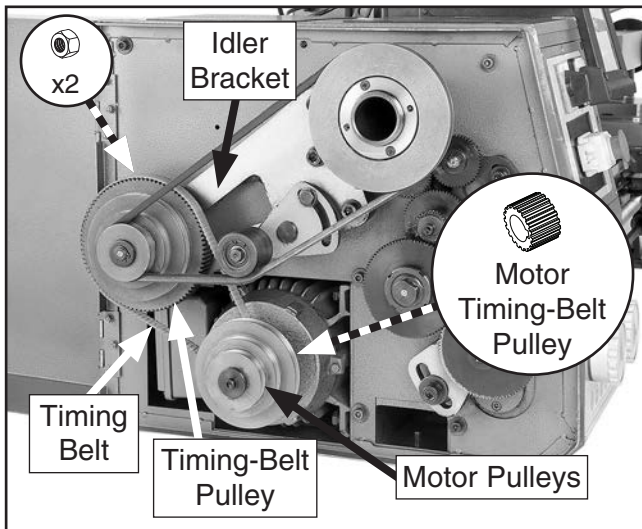

Figure 15. Timing belt installation components.

3. Place timing belt behind motor pulley and around motor timing-belt pulley (see **Figure 15**).
4. Install free end of timing belt on timing-belt pulley (see **Figure 15**), making sure teeth of belt mesh with notches in pulley.
5. Pull timing-belt up, creating tension in timing belt, then tighten (2) hex nuts from **Step 1**.
6. Loosen M8-1.25 x 25 hex bolt that secures tensioner to timing gear bracket (see **Figure 16**).

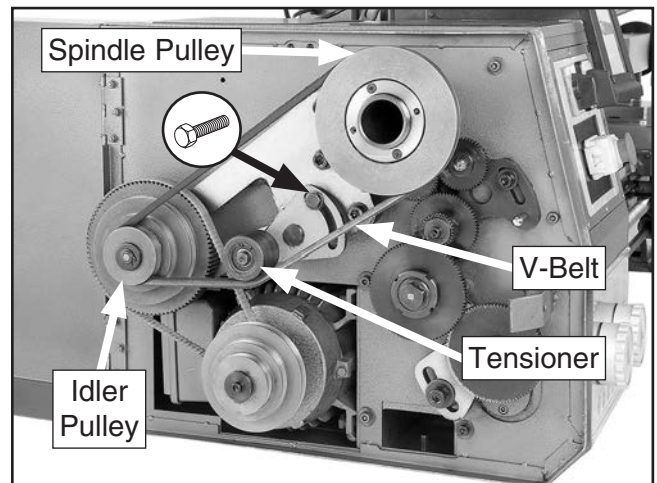

Figure 16. V-belt controls and components.

7. Install V-belt onto largest spindle pulley groove and smallest idler pulley groove, as shown in **Figure 16**.
8. Pivot tensioner against V-belt to create tension (see **Figure 16**) and re-tighten hex bolt from **Step 1**.

Note: The V-belt/pulley configuration of Model G0773 varies depending on spindle speed. The steps above illustrate V-belt installation for 150 RPM, which is the starting speed in the Lathe Spindle Break-In procedure on **Page 26**. For more detailed instructions on selecting proper configurations for specific spindle speeds, see *Setting Spindle Speed* on **Page 41**.



Test Run

Once assembly is complete, test run the machine to ensure it is properly connected to power and safety components are functioning properly.

If you find an unusual problem during the test run, immediately stop the machine, disconnect it from power, and fix the problem BEFORE operating the machine again. The **Troubleshooting** table in the **SERVICE** section of this manual can help.

⚠ WARNING

Serious injury or death can result from using this machine BEFORE understanding its controls and related safety information. DO NOT operate, or allow others to operate, machine until the information is understood.

⚠ WARNING

DO NOT start machine until all preceding setup instructions have been performed. Operating an improperly set up machine may result in malfunction or unexpected results that can lead to serious injury, death, or machine/property damage.

To test run machine:

1. Make sure all tools and objects used during setup are cleared away from machine.
2. Press Emergency Stop button cover (see **Figure 17**) to prevent unexpected start up.

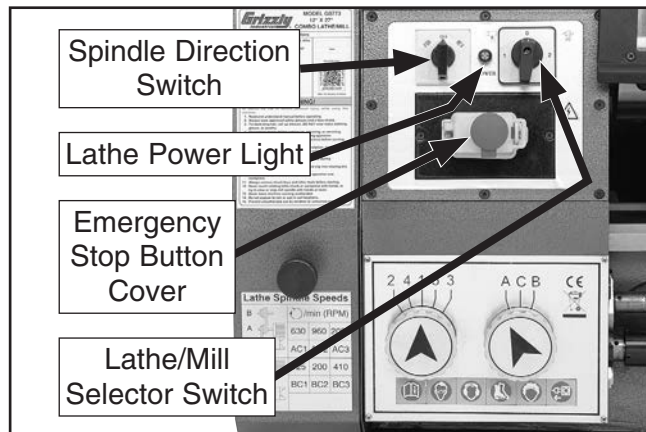

Figure 17. Headstock controls.

3. Set spindle direction switch to OFF position.
4. Set lathe/mill selector switch to "1".
5. Make sure chuck and jaws, if installed, are secure (see **Chuck Installation** on **Page 28**).

Note: If a chuck is not installed on the lathe, you do not need to install one for this test run.

6. Disengage half nut with lever by positioning lever as shown in **Figure 18**.

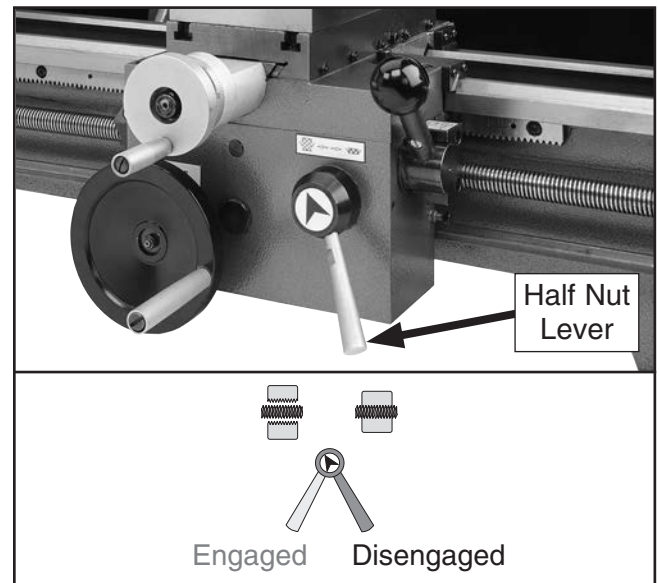

Figure 18. Half nut lever positioned to disengage half nut.

7. Connect machine to power. Lathe power light (**Figure 17**) should illuminate if machine is correctly connected to power supply and all electrical controls are positioned correctly for startup.



- Press tab on side of Emergency Stop button to open switch cover (see **Figure 19**), and reset switch by pressing green ON button (be sure to leave switch cover open; otherwise, closing it will prevent operation).

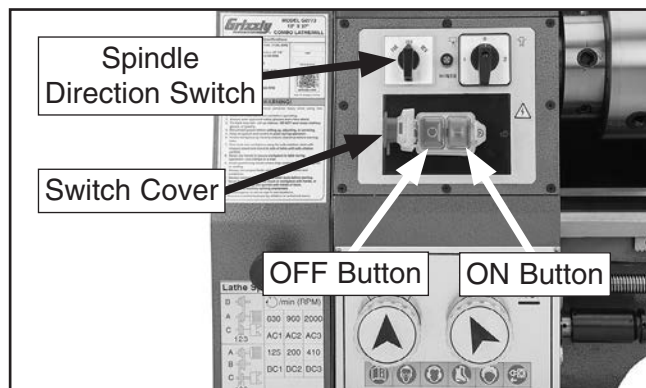

Figure 19. Emergency Stop button lathe.

- Turn spindle direction switch shown in **Figure 19** to "FOR" (forward) position. The spindle *should* rotate counterclockwise—down and toward front of lathe.

The machine should run smoothly with little to no vibration or rubbing noises.

—Strange or unusual noises should be investigated and corrected before operating machine further. Always disconnect machine from power when investigating or correcting potential problems.

- Press Emergency Stop button to turn lathe **OFF** and stop spindle rotation. Then, without resetting Emergency Stop button, try to restart spindle rotation by rotating spindle direction switch all the way clockwise and then counterclockwise. The spindle *should not* start if the Emergency Stop button is working correctly.

—If spindle *does* start with Emergency Stop button pressed in, the button is not operating correctly. To reduce the risk of injury, this safety feature must operate properly before further using the machine. Turn spindle direction switch OFF to stop lathe, disconnect lathe from power, and call Tech Support for help.

- Set lathe/mill selector switch to "2" for mill mode (see **Figure 17** on **Page 24**).

- Turn variable-speed dial (**Figure 20**) completely counterclockwise to lowest possible setting.

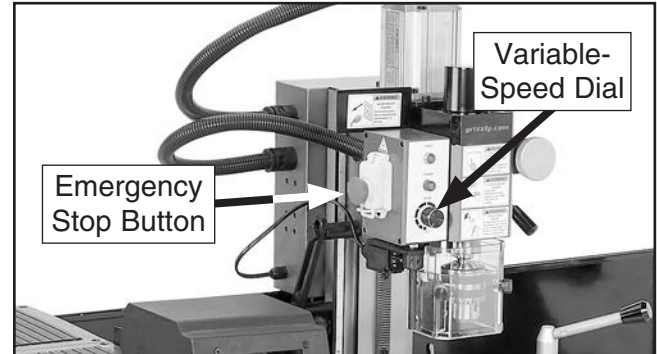

Figure 20. Location of mill head Emergency Stop button and variable-speed dial.

- Open Emergency Stop button switch cover (**Figure 20**) and reset switch in the same manner as you did in **Step 8**. The mill power light should illuminate if machine is correctly connected to power supply and all electrical controls are positioned correctly for startup.

- Turn mill **ON** by rotating variable-speed dial clockwise, then rotate dial all the way clockwise to achieve maximum spindle speed.

- Press Emergency Stop button to turn mill **OFF**. Then, without resetting Emergency Stop button, try to restart spindle rotation by rotating variable-speed dial all the way counterclockwise and then clockwise. The spindle *should not* start.

—If spindle *does* start with Emergency Stop button pressed in, the button is not operating correctly. This safety feature must operate properly before further using the machine. Turn spindle direction switch OFF to stop mill, disconnect machine from power, and call Tech Support for help.

Congratulations! The Test Run is complete! Now perform the **Spindle Break-In** procedure beginning on **Page 26**.



Spindle Break-In

The spindle break-in procedure distributes lubrication throughout the bearings to reduce the risk of early bearing failure if there are any "dry" spots or areas where lubrication has settled in the bearings. You **must** complete this procedure **before** placing operational loads on the spindle for the first time when the machine is new or if it has been sitting idle for longer than 6 months.

Always start the spindle break-in at the lowest speed to minimize wear if there *are* dry spots. Allow the spindle to run long enough to warm up and distribute the bearing grease, then incrementally increase spindle speeds, allowing the spindle to run the same amount of time at each speed, until reaching the maximum spindle speed. Following the break-in procedure in this progressive manner helps minimize any potential wear that could occur until lubrication is fully distributed.

NOTICE

You must complete this procedure to maintain the warranty. Failure to do this could cause rapid wear-and-tear of spindle bearings once they are placed under load.

Lathe Spindle Break-In

1. Successfully complete **Test Run** procedure beginning on **Page 24**.
2. Run lathe spindle at 150 RPM for minimum of 5 minutes in the forward ("FOR") direction, and then another 5 minutes in the reverse ("REV") direction.

Note: *During **Installing V-Belt** in the **Assembly** section on **Page 23**, spindle speed was set at 150 RPM.*

3. Press Emergency Stop Button to turn lathe **OFF**.

4. DISCONNECT MACHINE FROM POWER!
5. Set spindle speed to 1130 RPM and repeat the same process of running spindle for 5 minutes in each direction.

Note: *If necessary, refer to **Setting Spindle Speed** on **Page 41** for detailed instructions.*

6. Set spindle speed to 2100 RPM and repeat the process once again.

Congratulations! The lathe spindle break-in is complete.

Mill Spindle Break-In

1. Successfully complete **Lathe Spindle Break-In**.
2. Run mill spindle at lowest speed (100 RPM) for a minimum of 10 minutes.
3. Run mill spindle at highest speed (2500 RPM) for 10 minutes.
4. Rotate spindle speed dial all the way counter-clockwise to "0", then press Emergency Stop button.

Congratulations! The mill spindle break-in is complete.

Recommended Adjustments

The following adjustments have been made at the factory. However, because of the many variables involved with shipping, we recommend you verify these adjustments to ensure the best results:

Factory adjustments that should be verified:

- Tailstock alignment **Page 34**
- Cross slide backlash adjustment.....**Page 71**
- Leadscrew backlash.....**Page 71**
- Gib adjustments**Page 72**



SECTION 4: LATHE OPERATIONS

Operation Overview

The purpose of this overview is to provide the novice machine operator with a basic understanding of how the machine is used during operation, so the machine controls/components discussed later in this manual are easier to understand.

Due to the generic nature of this overview, it is **not** intended to be an instructional guide. To learn more about specific operations, read this entire manual and seek additional training from experienced machine operators, and do additional research outside of this manual by reading "how-to" books, trade magazines, or websites.

	! WARNING To reduce your risk of serious injury, read this entire manual BEFORE using machine.
--	---

! WARNING To reduce risk of eye or face injury from flying chips, always wear approved safety glasses and face shield when operating this machine.	
	

NOTICE If you are not experienced with this type of machine, WE STRONGLY RECOMMEND that you seek additional training outside of this manual. Read books/magazines or get formal training before beginning any projects. Regardless of the content in this section, Grizzly Industrial will not be held liable for accidents caused by lack of training.
--

To complete a typical lathe operation, the operator does the following:

1. Securely mounts workpiece in lathe.
2. Puts on safety glasses and a face shield, rolls up sleeves, removes jewelry, and secures any clothing, jewelry, or hair that could get entangled in moving parts.
3. Installs tooling on toolpost, then backs it away to establish a safe startup clearance.
4. Removes all setup tools from lathe.
5. Checks for safe clearances by rotating workpiece by hand at least one full revolution.
6. Moves slides to where they will be used during operation.
7. If using power feed, selects appropriate feed rate and direction.
8. Sets spindle speed according to workpiece size and material.
9. Starts spindle rotation and uses carriage handwheels or power feed options to move tooling into workpiece for operations.
10. When finished turning, rotates spindle direction switch to OFF, presses Emergency Stop button, then removes workpiece.



Chuck Mounting

This lathe is equipped with a D1-type spindle nose. This type of spindle uses camlocks that are adjusted with a chuck key to securely mount a chuck or faceplate with repeatable precision and ease.

!WARNING

Never use spindle speeds faster than chuck RPM rating or safe limits of your workpiece. Excessive spindle speeds greatly increase risk of workpiece or chuck being thrown from machine with deadly force!

This lathe ships with the 3-jaw chuck installed. This is a scroll-type chuck where all three jaws move in unison when the chuck key is used.

Installation & Removal Device

Place a piece of plywood over the bedways to protect them from damage if a chuck or other tooling is dropped (see below).

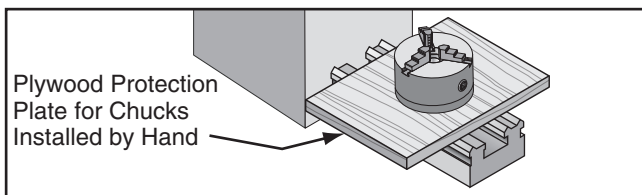

Figure 21. Example of common device used during chuck installation and removal.

Chuck Installation

To ensure accurate work, it is extremely important to make sure the spindle nose and chuck mating surfaces/tapers are clean. Even a small amount of lint or debris can affect accuracy.

The chuck is properly installed when all camlocks are tight, the spindle and chuck tapers firmly lock together, and the back of the chuck is firmly seated against the face of the spindle all the way around—without any gaps.

To install chuck:

1. DISCONNECT LATHE FROM POWER!
2. Use appropriate lifting, support, or protective device to protect ways and support chuck during installation process (refer to **Installation & Removal Devices** section on previous page).
3. Clean and lightly oil camlock studs, then thoroughly clean mating surfaces of spindle and chuck.
4. Install chuck by inserting camlock studs straight into spindle cam holes.

Important: Avoid inserting the studs by pivoting them in from an angle or rotating the spindle. This can damage studs or spindle cam holes.

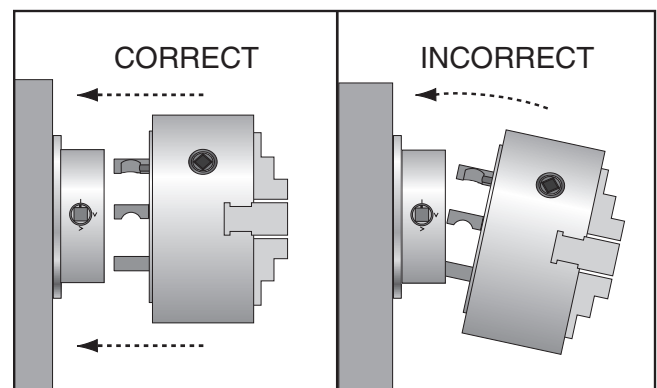

Figure 22. Inserting camlock studs into spindle cam holes.



5. Incrementally tighten camlocks in criss-cross or star pattern to ensure that chuck seats evenly against spindle.
6. When chuck is fully seated and all camlocks are tight, verify that cam line is between the two "V" marks on spindle nose, as shown in following figure.

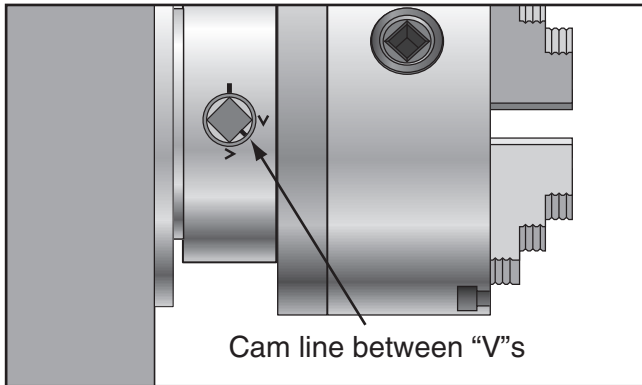

Figure 23. Cam line positioned between the "V" marks after the camlocks are fully tightened.

—If cam line is NOT between "V" marks when camlock is tight, stud may be installed at incorrect height. To fix this, adjust stud height as shown in following figure. Make sure to re-install stud cap screw afterward.

—If adjusting stud height does not correct problem, try swapping stud positions on chuck.

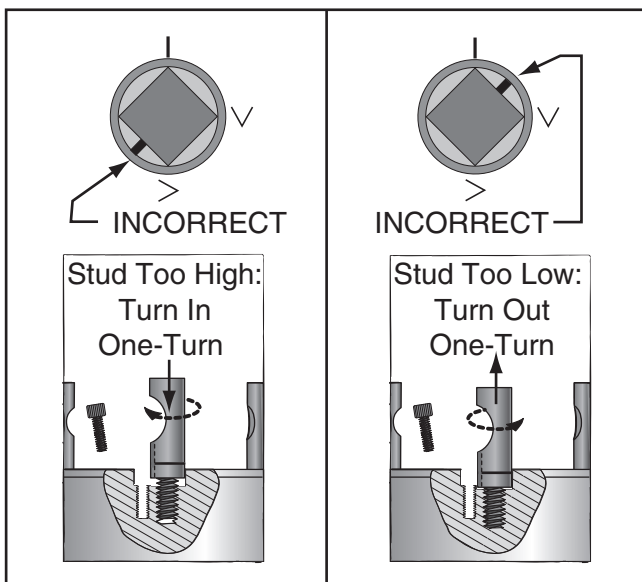

Figure 24. Correcting an improperly installed stud.

7. Verify that chuck fits spindle properly by checking for any gaps between mating surfaces.

—If there is not a gap, proceed to **Step 8**.

—If there is a gap, remove chuck, re-clean mating surfaces carefully, and re-install. If problem persists, contact our Tech Support.

8. Verify that chuck/spindle tapers are seated firmly together by removing chuck, per **Chuck Removal** instructions, and pay close attention to how easily tapers release.

—If it was necessary to bump chuck or use a mallet to release tapers, then they are seating together properly.

—If tapers released easily with little intervention, they are not seated together firmly as required. Remove chuck, re-clean mating surfaces carefully, and re-install. If problem persists, contact our Tech Support.

Registration Marks

Lightly stamp registration marks across the mating seams of chuck components. These marks will help you re-install the chuck in the same position after removal, which ensures consistent chuck balance and turning results, and allows the same camlocks and studs to operate together for consistent locking and unlocking.

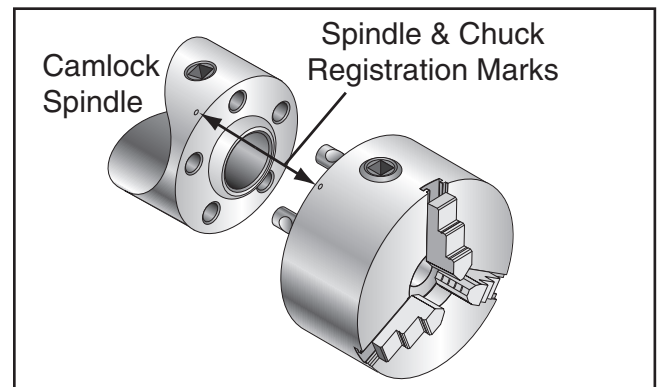

Figure 25. Registration mark locations.



Chuck Removal

To remove chuck:

1. DISCONNECT LATHE FROM POWER!
2. Use appropriate lifting, support, or protective device to protect ways and support chuck (refer to **Installation & Removal Devices** section for more details).
3. Loosen camlocks by turning key counter-clockwise until each cam line is aligned with its corresponding spindle mark, as shown below.

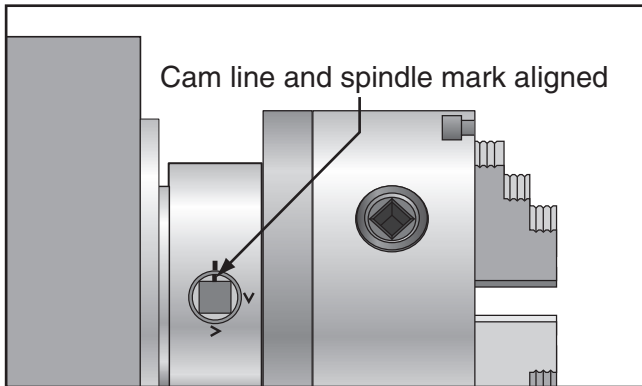

Figure 26. Camlock is fully loosened when the cam line is aligned with the spindle mark.

Tip: Camlocks can become very tight. A cheater pipe may be used as a last resort to add leverage when loosening. After loosening, you may need to wiggle the chuck key in the camlock to fully disengage the stud.

4. Using dead blow hammer or other soft mallet, lightly tap around outer circumference of chuck body to loosen it from spindle.
5. Remove chuck from spindle, using light rocking motion to carefully slide studs out of cam holes.

—If chuck does not immediately come off, rotate it approximately 60° and tap it again. Make sure all marks on cams and spindle are properly aligned for removal.

Scroll Chuck Clamping

This 3-jaw, scroll-type chuck has an internal scroll-gear that moves all jaws in unison when adjusted with the chuck key. This chuck holds cylindrical parts on-center with the axis of spindle rotation and can be rotated at high speeds if the workpiece is properly clamped and balanced.

Never mix jaw types or positions to accommodate an odd-shaped workpiece. The chuck will spin out of balance and may throw the workpiece! Instead, use an independent jaw chuck or a faceplate.

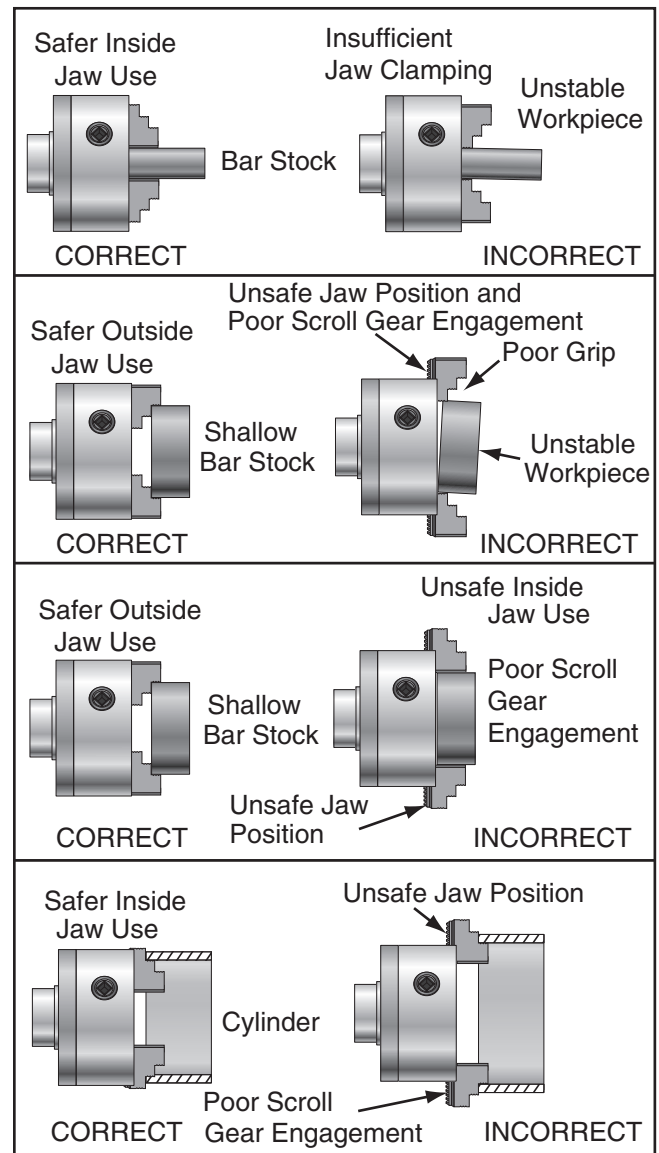

Figure 27. Jaw selection and workpiece holding.



Changing Jaw Set

The 3-jaw scroll chuck included with the lathe features inside and outside hardened steel jaw sets (see **Figure** below), which move in unison to center a concentric workpiece.

When installing the jaws, it is important to make sure they are installed correctly. Incorrect installation will result in jaws that do not converge evenly and are unable to securely clamp a workpiece.

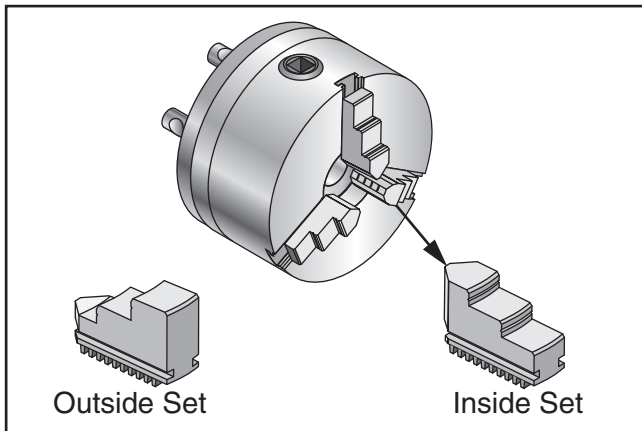

Figure 28. Chuck and jaw selection.

Jaws are numbered from 1–3 (see **Figure** below). The number is typically stamped on the side or bottom. Jaws are designed to be installed counterclockwise in numerical order in the matching numbered jaw guides, so they will hold a concentric workpiece evenly.

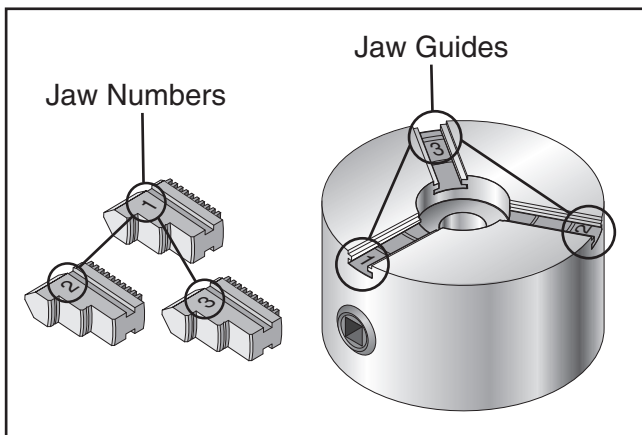

Figure 29. Jaw guide and jaw numbers.

To change jaw set:

1. DISCONNECT MACHINE FROM POWER!
2. Use appropriate device to protect ways (refer to **Installation & Removal Device** subsection).
3. Insert chuck key and turn it counterclockwise to back jaws out and remove them individually in descending order (i.e., 3, 2, 1).
4. Use mineral spirits to clean debris and grime from jaws and chuck jaw guides.
5. Apply thin coat of NLGI #2 grease to surfaces of removed jaw set. Store in safe place free from moisture and abrasives.
6. Rotate chuck key clockwise until you see tip of outer scroll-gear lead thread about to enter a jaw guide (see below).

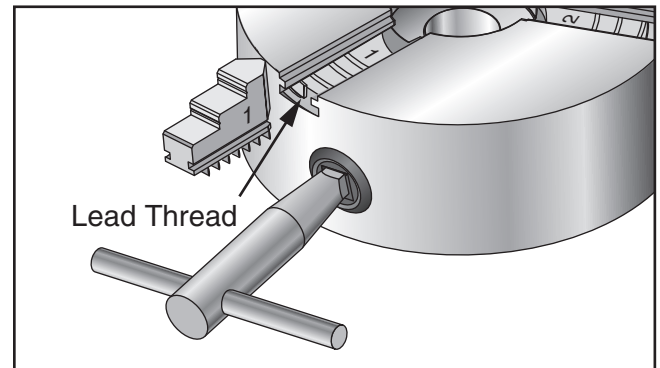

Figure 30. Lead thread on scroll gear.

7. Insert jaw #1 into jaw guide #1 and hold jaw against scroll-gear.
8. Rotate chuck key clockwise one turn to engage tip of scroll-gear lead thread into jaw. Pull jaw; it should be locked into jaw guide.
9. Install remaining jaws in numerical order, in the same manner. The jaws should converge evenly at center of chuck.

—If jaws do not converge evenly, remove them. Check that jaw numbers and jaw guides match. Re-install jaws sequentially 1–3, making sure each one engages with scroll-gear lead thread during its first rotation.



Tailstock

The tailstock is typically used to support long workpieces at the side opposite the spindle, using a live or dead center. It can also hold a tapered drill bit (or a drill chuck with a regular drill bit) for boring holes. Unlike boring done with a drill press where the workpiece is fixed and the drill bit rotates, the drill bit in a tailstock remains stationary while the workpiece is rotated by the spindle.

The entire tailstock can be repositioned and locked in place along the length of the bed. An independently controlled offset adjustment allows the upper part of the tailstock to move perpendicular to the bedways so it can be aligned with the spindle center (for concentric turning) or offset from the spindle center (for tapered turning).

The tailstock quill also features independent adjustment controls that allow it to be advanced toward the spindle or locked firmly in position.

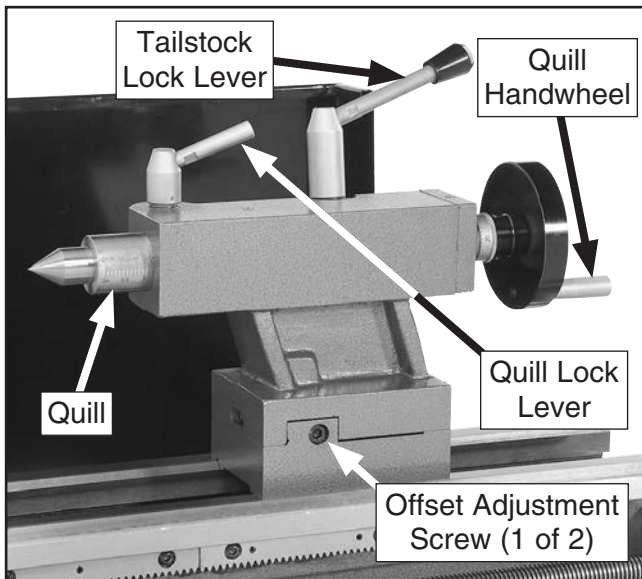

Figure 31. Tailstock controls and features.

Tailstock Quill Specs

Graduated Dial on Handwheel

Increments..... 0.001"
One Full Revolution..... 0.04"

Increments on Quill Scale

Inch 0"-2" in 0.10" Increments
Metric 0-50mm in 1mm Increments

Positioning Tailstock

1. Rotate tailstock lock lever clockwise (facing machine) to unlock tailstock from bedways.
2. Slide tailstock to desired position by pushing it along the bedways.
3. Rotate tailstock lock lever counterclockwise to lock tailstock against bedways.

Using Quill

1. Rotate quill lock lever counterclockwise to loosen quill.
2. Turn quill handwheel clockwise to move quill toward spindle or counterclockwise to move it away from spindle.
3. Rotate quill lock lever clockwise to secure quill.



Installing Tooling

The tailstock quill accepts MT#3 tapered arbors (see the **Figures** below for examples).

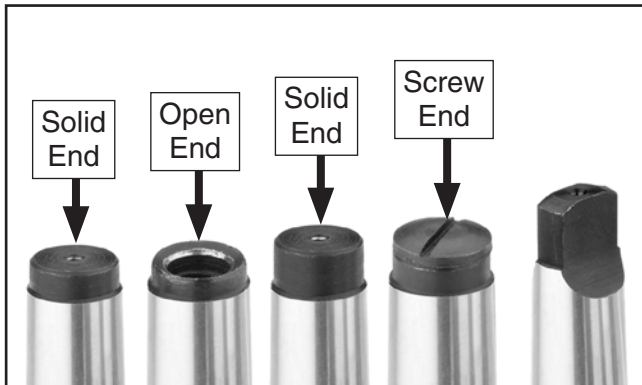

Figure 32. Types of tapered arbors and tooling.

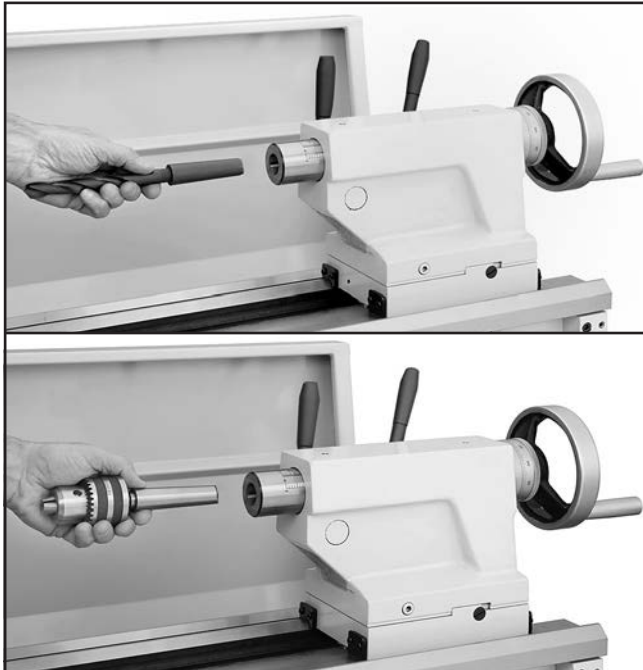

Figure 33. Example photos of inserting tools into the tailstock.

Note: *If the tooling has an open hole in the end, then a screw can be threaded into the end of the tool to provide a solid surface for the quill pin to push against when the quill is retracted for tool removal. Otherwise, removal of such tooling may be difficult.*

To install tooling in the tailstock:

1. With tailstock locked in place, unlock quill, then use handwheel to extend it approximately 1".
2. Thoroughly clean and dry tapered mating surfaces of quill and center, making sure no lint or oil remains on tapers.
3. With a firm and quick motion, insert tool into quill. Check to see if it is firmly seated by attempting to twist it—a firmly seated tool will not twist.
4. Unlock tailstock and move it until tip of tool is close to, but not touching, workpiece, then lock tailstock.
5. Start spindle rotation, unlock quill lock lever, then turn quill handwheel clockwise to feed tool into workpiece.

Removing Tooling

1. Use shop rag to hold tool.
2. Rotate quill handwheel counterclockwise to fully retract quill into tailstock until tool is forced out of quill.



Offsetting Tailstock

The tailstock quill can be offset from the spindle centerline for turning tapers. Offsetting quill toward the front of the lathe results in a taper at the tailstock end. Conversely, offsetting quill toward the back of the lathe results in a taper at the spindle end.

Note: *The marks on the offset indicator are arbitrary. For a precise offset, use a dial indicator to check quill movement while adjusting the screws.*

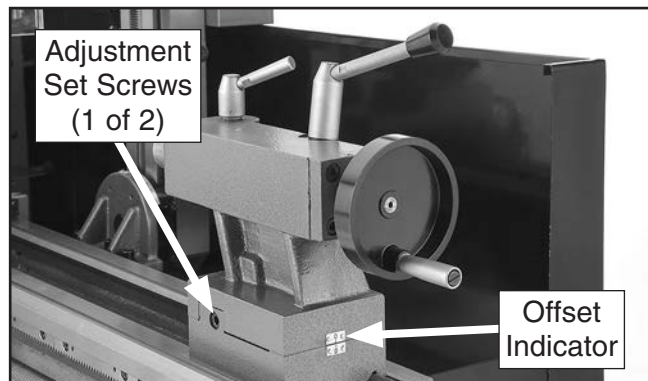

Figure 34. Tailstock offset adjustment.

Tool Needed	Qty
Hex Wrench 4mm.....	1

To offset the tailstock:

1. Loosen tailstock lock to release clamping pressure on top and bottom castings.
2. Rotate adjustment set screws in opposite directions for desired offset (see below).

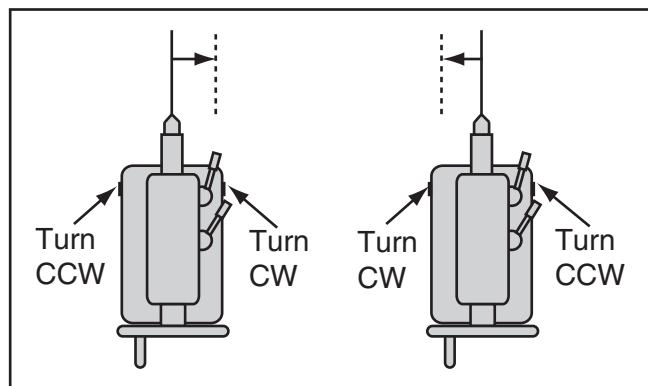

Figure 35. Example of set screw adjustment in relation to tailstock movement.

3. Tighten tailstock lock to secure the offset.

Aligning Tailstock to Spindle Centerline

This is an essential adjustment that should be verified or performed each time the tailstock is used to turn concentric workpieces between centers or immediately after offsetting the tailstock when turning a taper. If the tailstock is not aligned with the spindle centerline when it is supposed to be, turning results will be inaccurate along the length of the workpiece.

Items Needed	Qty
Hex Wrench 4mm.....	1
Round Stock 2" x 6"	2

To align tailstock to spindle centerline:

1. Use precision level to make sure bedway is level from side to side and from front to back.
 - If bedway is not level, correct this condition before continuing with this procedure (refer to **Leveling** section in this manual).
2. Center drill both ends of a piece of round stock, then set it aside for use in **Step 5**.
3. Use another piece of round stock to make a dead center. Turn it to a 60° point, as illustrated in below.

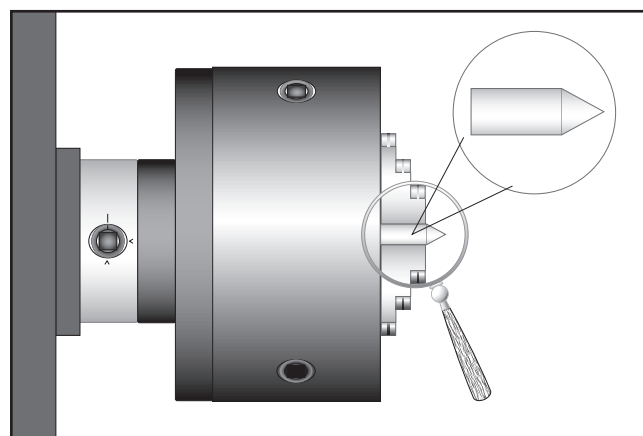

Figure 36. Turning a dead center.

Note: *As long as this dead center remains unmoved in the chuck, its point will remain true to the spindle centerline. However, if the center is removed and later returned to the chuck, the point must be re-turned to once again be true with the spindle centerline.*



4. Install center in tailstock.
5. Attach lathe dog to test stock from **Step 2**, then mount it between centers, as shown below.



Figure 37. Example of stock mounted between the centers.

6. Turn 0.010" off stock diameter.
7. Mount test or dial indicator so that plunger is on tailstock quill.

Note: If necessary in the following step, refer to the **Offsetting Tailstock** subsection for detailed instructions.

8. Use calipers to measure both ends of work-piece.

—If test stock is *thicker* at tailstock end, move tailstock toward *front* of lathe $\frac{1}{2}$ the distance of taper amount, as shown below.

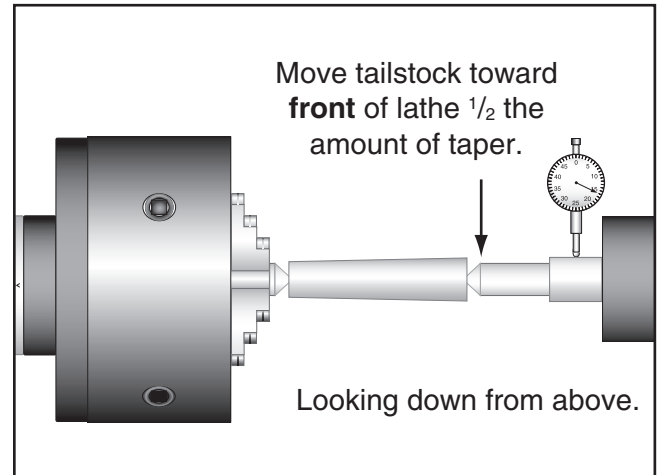

Figure 38. Adjust tailstock toward the operator.

—If test stock is *thinner* at tailstock end, move tailstock toward *back* of lathe $\frac{1}{2}$ the distance of the amount of taper, as shown below.

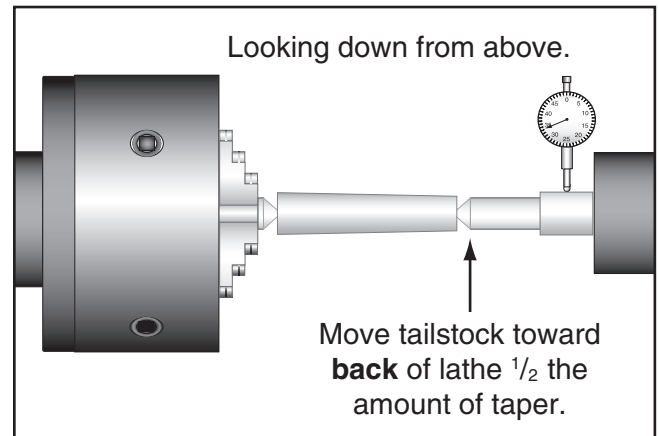

Figure 39. Adjust tailstock away from operator.

9. Repeat **Steps 6–8** until desired accuracy is achieved.



Dead Centers

A dead center is a one-piece center that, when mounted in the tailstock, does not rotate with the workpiece and is used to support long, slender workpieces.

Use the dead center in the spindle for operations where the workpiece rotates with the center and does not generate friction.

Figure 40 shows the MT#3 and MT#5 dead centers included with the lathe.

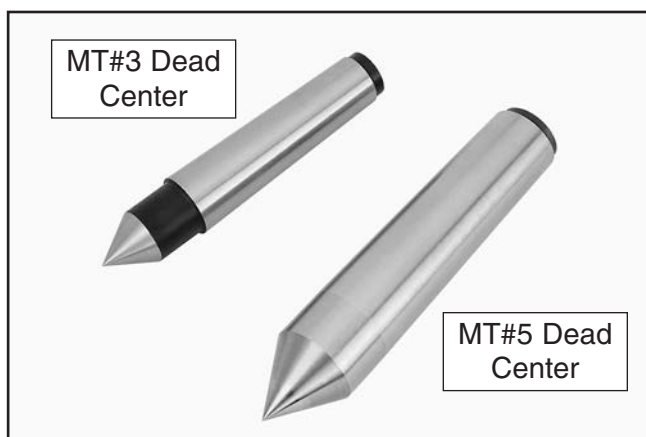

Figure 40. Dead centers.

Mounting Dead Center in Spindle

1. DISCONNECT LATHE FROM POWER!
2. Thoroughly clean and dry all threads and mating surfaces of spindle bore and center, making sure that no lint or oil remains on these surfaces.

Note: *This will prevent the tapered surfaces from seizing due to operational pressures, which could make it very difficult to remove the center.*
3. Mount chuck or faceplate onto spindle, whichever is correct for your operation.
4. Insert center into spindle bore through chuck or faceplate.

The **Figure** below shows an example photo of a dead center installed in spindle, using a lathe dog and faceplate for turning between centers.

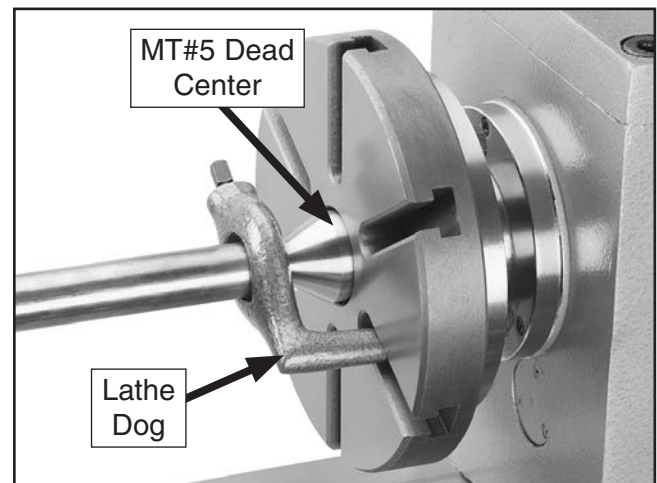

Figure 41. Example of using a dead center with a faceplate and lathe dog.

Removing Center from Spindle

To remove the sleeve and center from the spindle, insert a piece of round bar stock (or similar) through the outside end of the spindle. Have another person hold onto the sleeve and center with a gloved hand or shop rag, then tap the bar stock to knock the sleeve loose.



Mounting Center in Tailstock

Either a carbide-tipped dead center or live center can be used in the tailstock. Mounting instructions are the same for both. The **Figure** below shows an example photo of a dead center mounted in a tailstock.

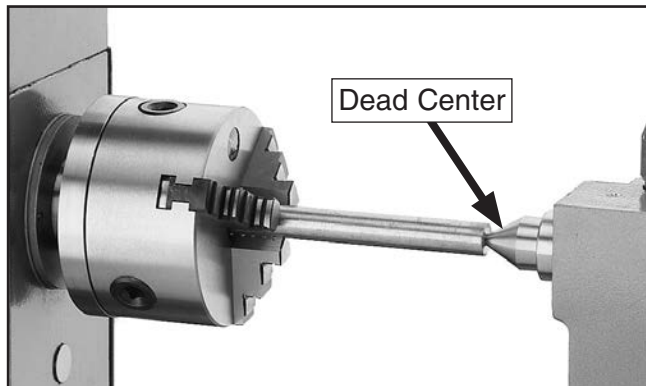

Figure 42. Example of using dead center installed in the tailstock.

To mount center in tailstock:

1. DISCONNECT MACHINE FROM POWER!
2. Thoroughly clean and dry tapered mating surfaces of tailstock quill bore and center, making sure no lint or oil remains on tapers.
3. Use quill handwheel to feed quill out from casting approximately 1".

Note: *The maximum quill travel is 3.2", but we do not recommend extending the quill more than 1" or stability and accuracy will be reduced.*

4. Insert center into tailstock quill.
5. Seat center firmly into quill during workpiece installation by rotating quill handwheel clockwise to apply pressure with center engaged in center hole of workpiece.

Note: *Only apply enough pressure with tailstock quill to securely mount workpiece between centers. Avoid overtightening center against workpiece, or it may become difficult to remove later, and it will result in excessive friction and heat, which may damage workpiece and center.*

Removing Center from Tailstock

To remove the center from the quill, hold onto it with a gloved hand or shop rag, then rotate the quill handwheel counterclockwise to draw the quill back into the casting until the center releases.

Mounting Workpiece Between Centers

1. DISCONNECT LATHE FROM POWER!
2. Drill center holes in both ends of workpiece.
3. Install dead center in spindle with lathe dog and chuck, faceplate or drive plate, then install live center or carbide-tipped dead center in tailstock.
4. Lubricate dead center point and workpiece center holes, then mount workpiece between centers and hold it in place with light pressure from tailstock center.
5. Seat center firmly into quill by rotating quill handwheel clockwise to apply pressure against workpiece (see example below).



Figure 43. Example photo of a workpiece mounted between two centers.

Note: *Only apply enough pressure to securely mount the workpiece between centers. Avoid over-tightening the center against the workpiece, or it may become difficult to remove later. Also, over-tightening will result in excessive friction and heat, which may damage the workpiece or center.*



Compound Rest

The compound rest handwheel has an indirect-read graduated scale. This means that the distance shown on the scale represents the actual distance the cutting tool moves. The base of the compound rest has another graduated scale used for setting the cutting tool to a specific angle.

Graduated Dial

Increments..... 0.001" (0.025mm)
 One Full Revolution..... 0.08" (2.03mm)

Tool Needed	Qty
Hex Wrench 6mm.....	1

To set compound rest angle:

1. Loosen cap screws shown in **Figure 44**.

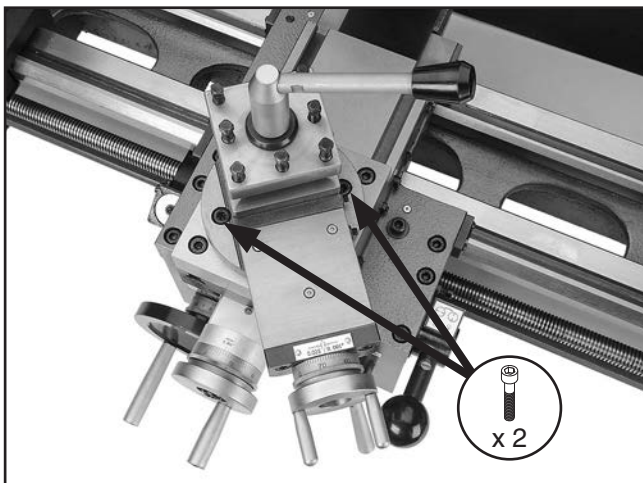

Figure 44. Compound rest angle adjustments.

2. Rotate rest to desired angle, as indicated by scale at base, then retighten cap screws.

Tip: *The first time you set the compound rest angle for cutting threads, mark the location on the cross slide as a quick reference point. This will allow you to quickly return the compound rest to that exact angle the next time you need to cut threads.*

Four-Way Tool Post

The four-way tool post is mounted on top of the compound rest and allows a maximum of four tools to be loaded simultaneously.

Each tool can be quickly indexed to the workpiece by loosening the top handle, rotating the tool post to the desired position, then retightening the handle to lock the tool into position.

Installing Tool

Tool Needed	Qty
Tool Post T-Wrench	1

To install a tool in tool post:

1. Adjust tool post bolts so cutting tool can fit underneath them (see below).

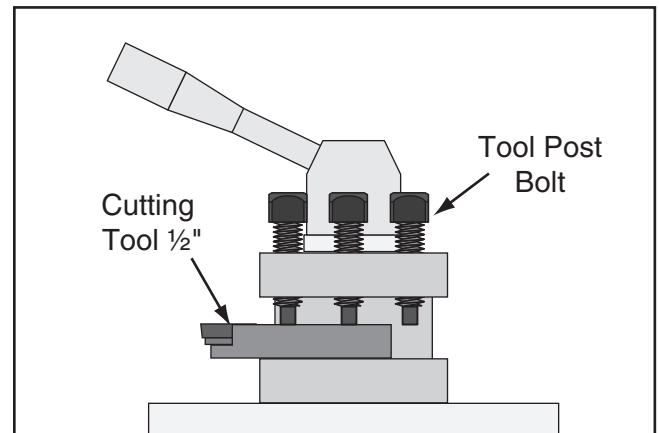

Figure 45. Example of tool mounted in tool post.

⚠️ WARNING

Over-extending a cutting tool from the post will increase risk of tool chatter, breakage, or tool loosening during operation, which could cause metal pieces to be thrown at the operator or bystanders with great force. DO NOT extend a cutting tool more than 2.5 times the width of its cross-section (e.g., 2.5 x 0.5" = 1.25").

2. Firmly secure cutting tool with at least two tool post bolts.
3. Check and adjust cutting tool to spindle centerline, as instructed in next subsection.



Aligning Cutting Tool with Spindle Centerline

For most operations, the cutting tool tip should be aligned with the spindle centerline, as illustrated below.

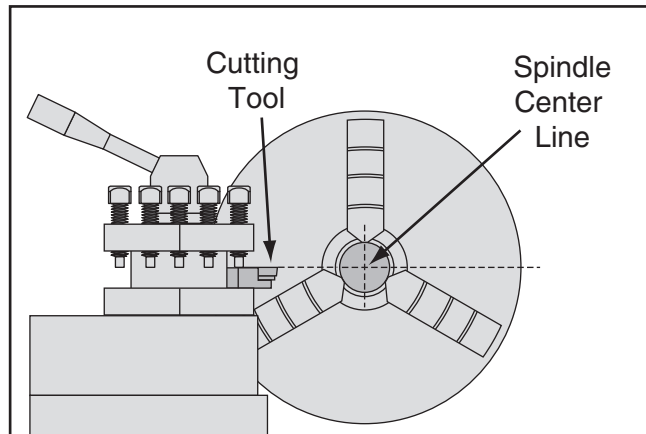

Figure 46. Cutting tool aligned with spindle centerline (viewed from tailstock).

There are a number of ways to check and align the cutting tool to the spindle centerline. If necessary, you can raise the cutting tool by placing steel shims underneath it. The shims should be as long and as wide as the cutting tool to properly support it.

Below are two common methods:

- Move the tailstock center over the cross slide and use a fine ruler to measure the distance from the surface of the cross slide to the tip of the center. Adjust the cutting tool height so it is the same distance above the cross slide as the tailstock center.
- Align the tip of the cutting tool with a tailstock center, as instructed in the following procedure. For this to work, the tailstock must be aligned to the spindle centerline (refer to **Aligning Tailstock To Spindle Centerline** in this manual for detailed instructions).

Tools Needed	Qty
Tool Post T-Wrench	1
Steel Shims	As Needed
Cutting Tool	1
Tailstock Center	1

To align cutting tool with tailstock center:

1. Mount cutting tool in tool post, then secure post so tool faces tailstock.
2. Install center in tailstock, and position center tip near cutting tool tip.
3. Lock tailstock and quill in place.
4. Adjust height of cutting tool so tool tip is aligned vertically with center tip, as illustrated below.

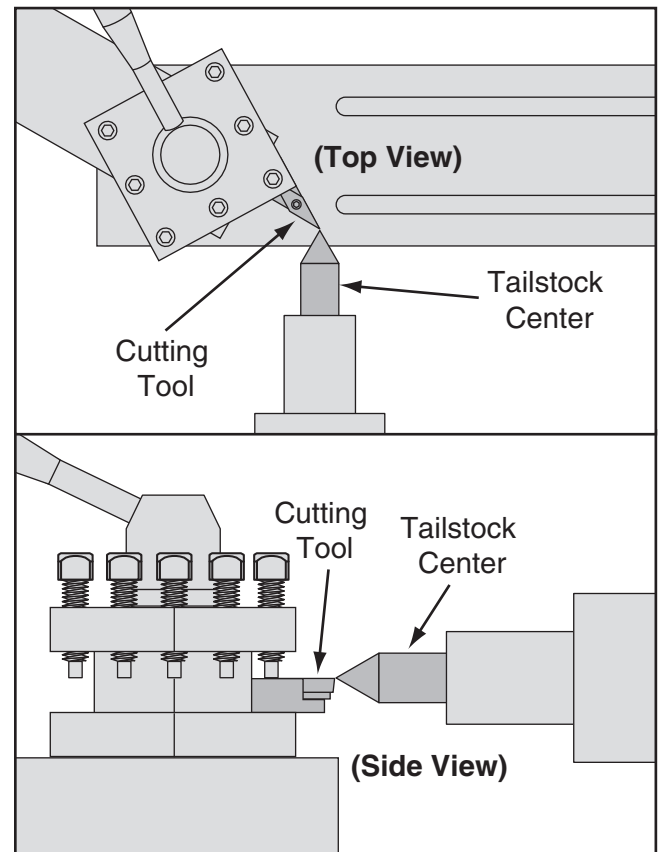

Figure 47. Cutting tool aligned to the tailstock center.



Manual Feed

The cutting tool can be manually fed into the workpiece using the carriage, cross slide, and compound rest handwheels shown below.

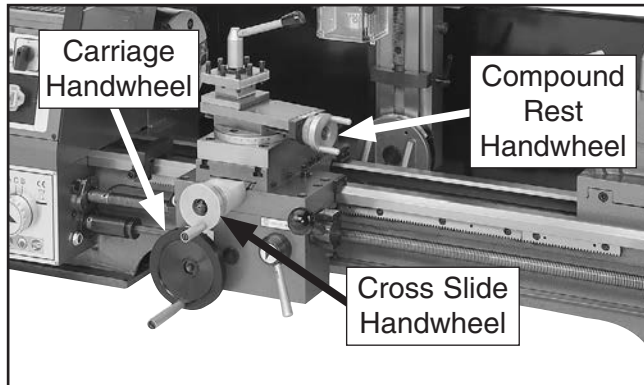

Figure 48. Manual feeding controls.

Carriage Handwheel

Graduated Dial

Increments.....0.08" (2.03mm)
One Full Revolution.....1.5" (38.1mm)

Use the carriage handwheel to move the carriage left or right along the bed. Adjust the position of the graduated scale by holding the handwheel with one hand and turning the dial with the other.

Cross Slide Handwheel

Graduated Dial

Increments..... 0.001" (0.025mm)
One Full Revolution.....0.08" (2.03mm)

Use this handwheel to move the tool toward and away from the work. The cross slide handwheel has an indirect-read graduated dial, which shows the actual distance the table moves.

Compound Rest Handwheel

Graduated Dial

Increments 0.001" (0.025mm)
One Full Revolution.....0.08" (2.03mm)

Use this handwheel to move the cutting tool linearly along the set angle of the compound rest. Set the compound rest angle by hand-rotating it and securing it with the two cap screws (see **Figure 44** on **Page 38**). The compound rest has an indirect-read graduated dial, which shows the actual distance the tool moves.



Spindle Speed

Using the correct spindle speed is important for getting safe and satisfactory results, as well as maximizing tool life.

To set the spindle speed for your operation, you will need to: 1) Determine the best spindle speed for the cutting task, and 2) Configure the lathe controls to produce the required spindle speed.

Determining Spindle Speed

Many variables affect the optimum spindle speed to use for any given operation, but the two most important are the recommended cutting speed for the workpiece material and the diameter of the workpiece, as noted in the formula shown below.

$\frac{\text{*Recommended Cutting Speed (FPM)} \times 12}{\text{Dia. of Cut (in inches)} \times 3.14} = \text{Spindle Speed (RPM)}$
<p>*Double if using carbide cutting tool</p>

Figure 49. Spindle speed formula for lathes.

Cutting speed, typically defined in feet per minute (FPM), is the speed at which the edge of a tool moves across the material surface.

A recommended cutting speed is an ideal speed for cutting a type of material in order to produce the desired finish and optimize tool life.

The books **Machinery's Handbook** or **Machine Shop Practice**, and some internet sites, provide excellent recommendations for which cutting speeds to use when calculating the spindle speed. These sources also provide a wealth of additional information about the variables that affect cutting speed and they are a good educational resource.

Also, there are a large number of easy-to-use spindle speed calculators that can be found on the internet. These sources will help you take into account the applicable variables in order to determine the best spindle speed for the operation.

Setting Spindle Speed

Spindle speed is selected by positioning the V-belt either between the spindle and motor pulleys (see **Figure 50**), or between the spindle and idler pulleys. Select the motor pulleys for high (720-2100 RPM) or idler pulleys for low (150-470 RPM) speed ranges. The V-belt diagram below is also found on the headstock.

Refer to **Tensioning & Replacing V-Belts** on **Page 70** for instructions on removing and re-installing V-belts.

Tool Needed	Qty
Hex Wrench 4mm.....	1

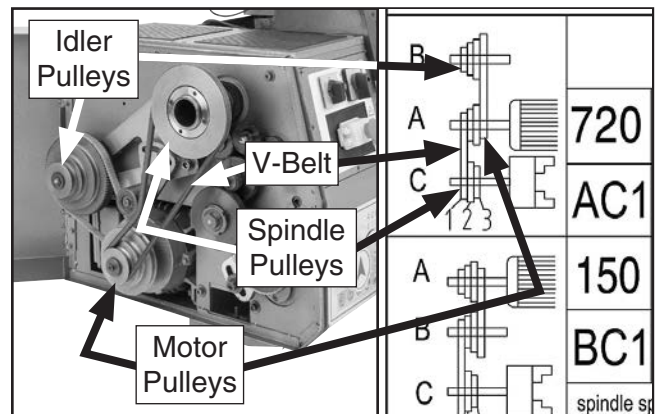

Figure 50. Belt positioned for 720 RPM.



Understanding Gear Charts

This subsection explains how to understand the feed and thread charts on the headstock. If you do not understand lathe gear charts, or need a quick refresher, read this before configuring the end gears for power feeding or threading operations.

Feed & Thread Charts Label

The feed and thread charts label (see **Figure 51**) provides information for setting up end gears for threading or non-threading operations. The top displays metric and inch thread charts, the bottom displays a feed chart.

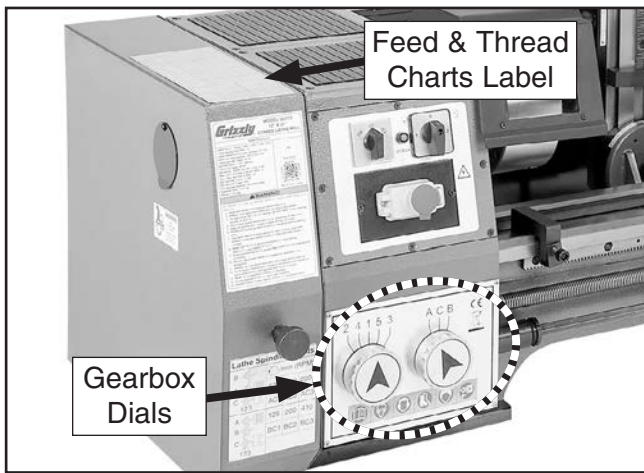

Figure 51. Feed and thread charts label.

Feed Chart—Displays gearbox dial positions for different speeds of automatic feed (power feed) used with turning operations (see **Figure 52**).

		INS / $\frac{1}{4}$			INS / $\frac{1}{8}$		
G	30			30			
Lever	A	B	C	A	B	C	
1	0.0016	0.0032	0.0064	0.0008	0.0017	0.0034	
2	0.0018	0.0036	0.0072	0.0010	0.0019	0.0038	
3	0.0021	0.0041	0.0082	0.0011	0.0022	0.0043	
4	0.0024	0.0048	0.0096	0.0013	0.0025	0.0051	
5	0.0029	0.0058	0.0115	0.0015	0.0030	0.0061	

Figure 52. Feed chart.

Thread Charts—Display headstock end gear positions used for cutting various metric or inch threads (see **Figure 53**).

		THREADS PER INCH					
G	30			60			
Lever	A	B	C	A	B	C	
1	72	36	18	36	18	9	
2	64	32	16	32	16	8	
3	56	28	14	28	14	7	
4	48	24	12	24	12	6	
5	40	20	10	20	10	5	

		THREADS mm					
G	30			35			
Lever	A	B	C	A	B	C	
1							
2		0.75	1.5			1.75	
3				0.5	1	2	
4	0.5	1	2				
5	0.6			0.7			

		THREADS PER INCH					
G	50			60			
Lever	A	B	C	A	B	C	
1							
2		1.25	2.5	0.75	1.5	3	
3							
4				1	2	4	
5	1	2	4				

		THREADS PER INCH		
G	30			
Lever	A	B	C	
1			19	

Figure 53. Threading charts.



How to Read the Feed Chart

Figure 54 identifies the fifteen available feed rates each for longitudinal and transverse carriage movement.



INS / 				INS / 		
G	30			30		
Lever	A	B	C	A	B	C
1	0.0016	0.0032	0.0064	0.0008	0.0017	0.0034
2	0.0018	0.0036	0.0072	0.0010	0.0019	0.0038
3	0.0021	0.0041	0.0082	0.0011	0.0022	0.0043
4	0.0024	0.0048	0.0096	0.0013	0.0025	0.0051
5	0.0029	0.0058	0.0115	0.0015	0.0030	0.0061

Figure 54. G0773 feed rate chart.

Figure 55 indicates that for a longitudinal feed rate of 0.0016 in/rev., the G position gear must be 30T, the numeric feed dial set to 1, and the alpha feed dial set to A (see **Figure 56**).

Longitudinal Feed Icon	
30T Gear in G Position	G 30
Numeric Feed Dial Set to 1	Lever 1
Feed Rate .0016 in/rev.	0.0016
Alpha Feed Dial Set to A	A

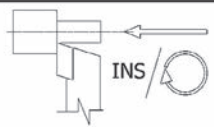
G	30		
Lever	A	B	C
1	0.0016	0.0032	0.0064
2	0.0018	0.0036	0.0072
3	0.0021	0.0041	0.0082
4	0.0024	0.0048	0.0096
5	0.0029	0.0058	0.0115

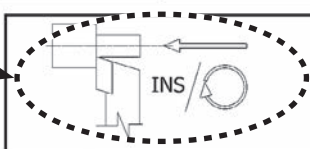
Figure 55. Reading feed chart.

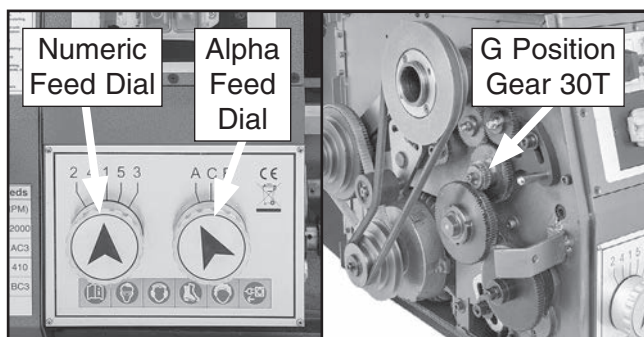

Figure 56. Feed dial and gear settings for 0.0016 in/rev.

How to Read the Thread Charts

Figure 57 identifies the charts to use when setting carriage feed movement for metric or inch threading.

THREADS PER INCH	
G	30 60
Lever	A B C A B C
1	72 36 18 36 18 9
2	64 32 16 32 16 8
3	56 28 14 28 14 7
4	48 24 12 24 12 6
5	40 20 10 20 10 5

THREADS mm	
G	30 35
Lever	A B C A B C
1	
2	0.75 1.5 1.75
3	
4	0.5 1 2 0.5 1 2
5	0.6 0.7

Figure 57. Headings indicate inch or metric threads.

Figure 58 shows the threads per inch (TPI) on the applicable chart.

THREADS PER INCH	
G	30 60
Lever	A B C A B C
1	72 36 18 36 18 9
2	64 32 16 32 16 8
3	56 28 14 28 14 7
4	48 24 12 24 12 6
5	40 20 10 20 10 5

Figure 58. Numbers in dotted line indicate the TPI or threads per inch.

Figure 59 identifies the end gears on the upper, middle, and lower shafts. The gears are represented by letters.

THREADS	
G	30
Lever	A B C
1	72 36 18
2	64 32 16
3	56 28 14
4	48 24 12
5	40 20 10

Figure 59. Identification of gears on shafts.



Figure 60 shows how the gearing illustration in the thread chart relates to the end gears.

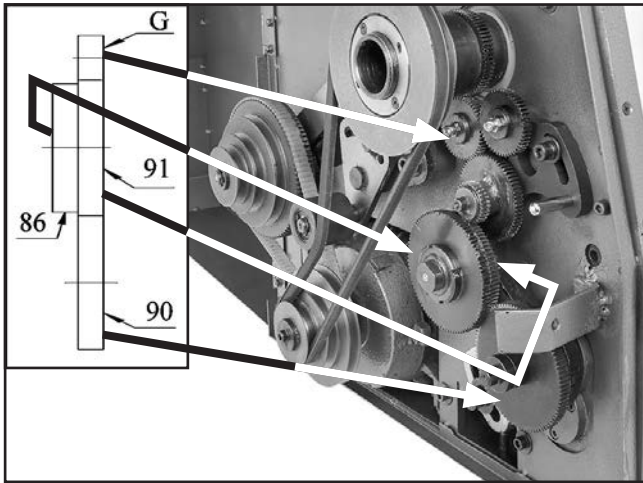

Figure 60. Power feed gearing setup.

Power Feed

The carriage has power feed (or automatic feed) options for threading or non-threading operations. This section describes how to use the power feed option for non-threading operations. To learn how to power the carriage for threading operations, refer to **Threading** on **Page 49**.

NOTICE

To avoid damaging lathe, **NEVER** allow cutting tool to run into chuck! **ALWAYS** make sure spindle is completely stopped **BEFORE** using headstock controls to make changes.

Power Feed Controls

Use the following descriptions and figures to understand the power feed controls.

Before using power feed, you may have to reconfigure the end gears, depending on how they are set up (refer to **Power Feed Configuration** on **Page 45**). The lathe comes from the factory with the end gears set up in the power feed configuration.

- A. Spindle Direction Switch:** Enables forward or reverse carriage travel when feed direction dial and half nut lever are engaged. The carriage will not move when the switch is in the "0" position.

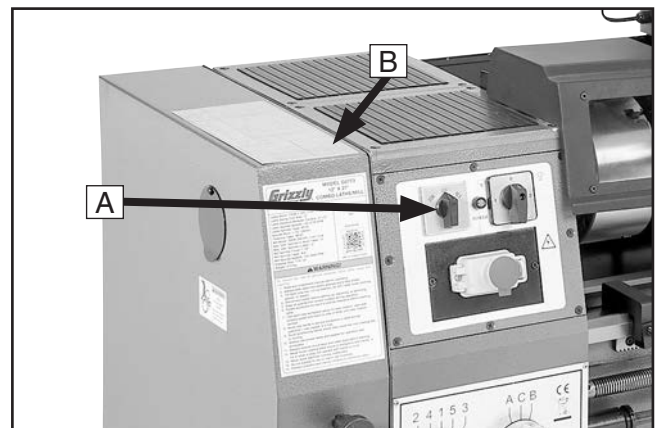

Figure 61. Spindle switch and feed rate chart.



B. Feed Rate Chart: Displays dial settings for selected feed rate (see **Figure 62**).

G	30			30		
Lever	A	B	C	A	B	C
1	0.0016	0.0032	0.0064	0.0008	0.0017	0.0034
2	0.0018	0.0036	0.0072	0.0010	0.0019	0.0038
3	0.0021	0.0041	0.0082	0.0011	0.0022	0.0043
4	0.0024	0.0048	0.0096	0.0013	0.0025	0.0051
5	0.0029	0.0058	0.0115	0.0015	0.0030	0.0061

Figure 62. Feed chart.

C. Half Nut Lever: Engages/disengages half nut for power feed operations.

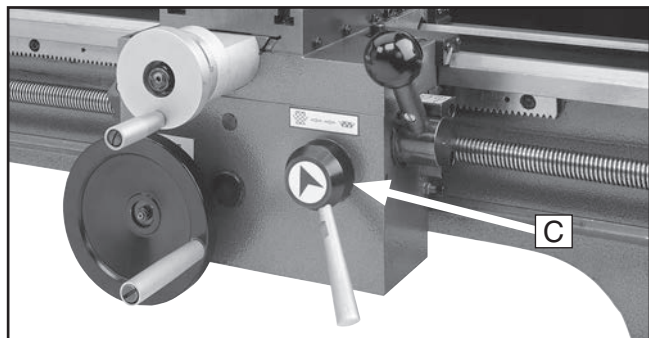

Figure 63. Half nut lever.

NOTICE

To avoid potential carriage/chuck crash, disengage half nut lever immediately after completing power feed operations.

Setting Power Feed Rate

Follow the example below to better understand how to set the lathe power feed.

Tools Needed

	Qty
Hex Wrench 5mm.....	1
Hex Wrench 8mm.....	1

To set a feed rate of 0.0016 in/rev.:

1. DISCONNECT MACHINE FROM POWER!
2. Install 30T change gear in "G" position (see **Figure 64**).

G	30			30		
Lever	A	B	C	A	B	C
1	0.0016	0.0032	0.0064	0.0008	0.0017	0.0034
2	0.0018	0.0036	0.0072	0.0010	0.0019	0.0038
3	0.0021	0.0041	0.0082	0.0011	0.0022	0.0043
4	0.0024	0.0048	0.0096	0.0013	0.0025	0.0051
5	0.0029	0.0058	0.0115	0.0015	0.0030	0.0061

30T Change Gear

0.0016 in/rev.

Figure 64. Reading feed chart for .0016 in/rev.

3. Set gearbox dials to positions "A" and "1", as shown in **Figure 65**.

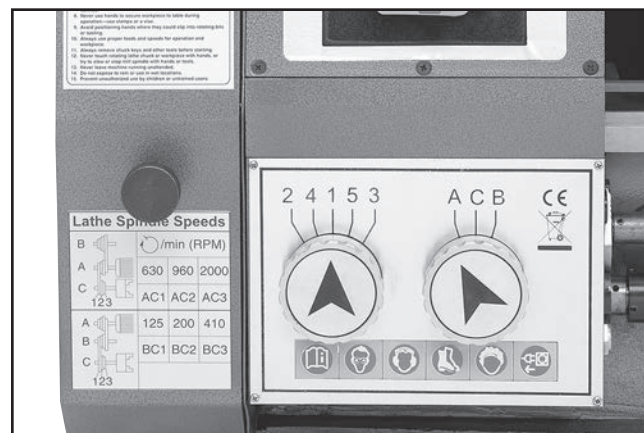

Figure 65. Gearbox dial settings for .0016 in/rev.



End Gears

This section explains how to configure end gears for feeding and threading operations.

Power Feed Configuration

The end gears are preset by the factory for power feeding (see **Figure 66**).

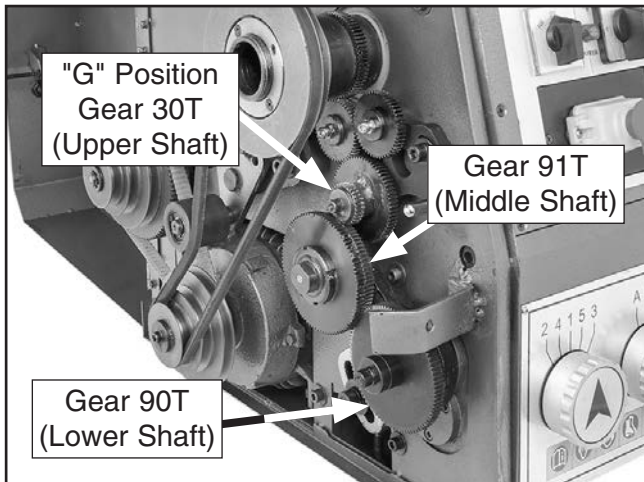

Figure 66. Gearing configuration for power feeding.

Primary Threading Configuration

This configuration is used for all inch threading except for 19TPI. Mesh the "G" position gear with the 91T change gear, and mesh the 91T change gear with the 90T gear on the lower shaft, as shown in **Figure 67**.

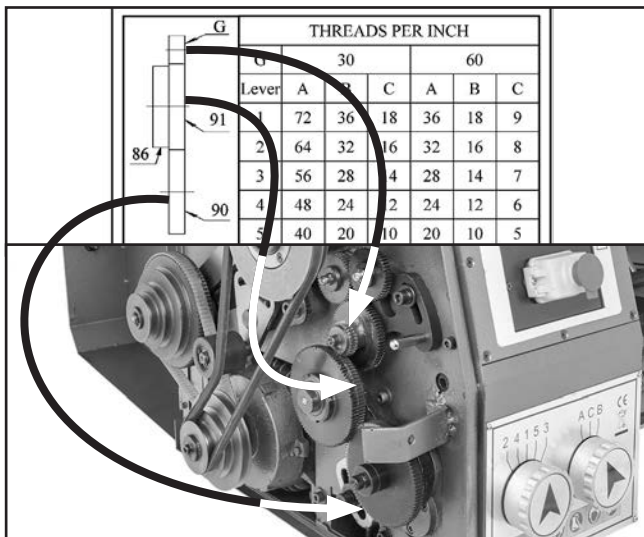

Figure 67. End gear configuration for inch threading.

Secondary Threading Configuration

This configuration is used for metric and 19TPI threading. Mesh the "G" position gear with the 91T change gear, and mesh the 86T change gear with the 90T gear on the lower shaft, as shown in **Figure 68**.

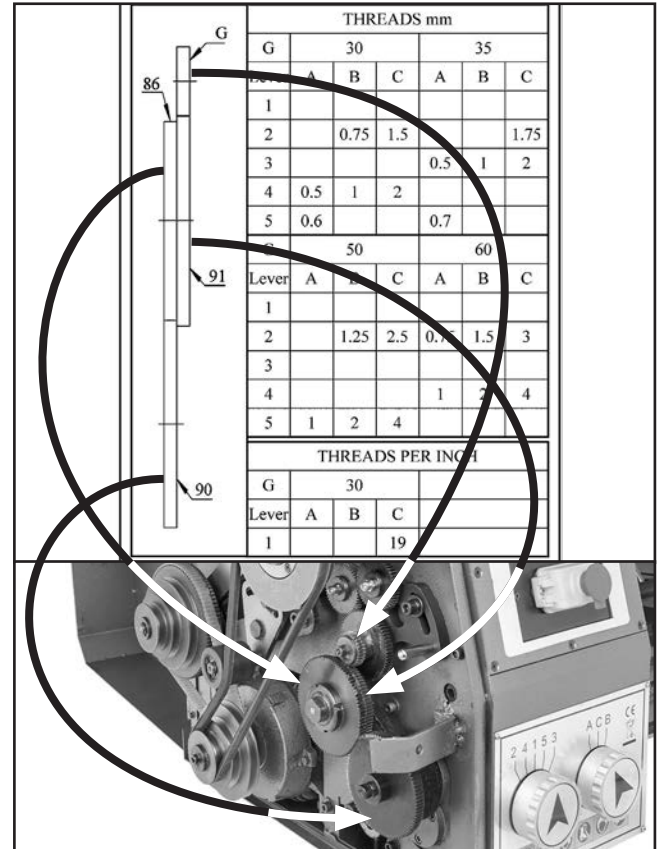

Figure 68. End gear configuration for metric and 19TPI threading.



End-Gear Configuration Example

Follow the example below to better understand how to configure the end gears for inch threading.

Tools Needed	Qty
Hex Wrench 5mm.....	1
Hex Wrench 6mm.....	1
Hex Wrench 8mm.....	1
Open-End Wrench 19mm.....	1

To configure end gears for threading 72 TPI:

1. Locate **72** on the metric thread chart, then locate the **30 "G"** position gear (see **Figure 69**), which corresponds to 1.5 metric thread pitch.

THREADS PER INCH						
	30			60		
Lever	A	B	C	A	B	C
1	72	36	18	36	18	9
2	64	32	16	32	16	8
3	56	28	14	28	14	7
4	48	24	12	24	12	6
5	40	20	10	20	10	5

THREADS mm						
	30			35		
Lever	A	B	C	A	B	C
1						
2		0.75	1.5			1.75

Figure 69. Locating change gears for 72 TPI.

2. DISCONNECT LATHE FROM POWER!
3. Open headstock end gear cover.
4. While holding **86T/91T** gears, loosen arm support cap screw shown in **Figure 70**, and slowly let gears pivot down and away from "G" position gear.

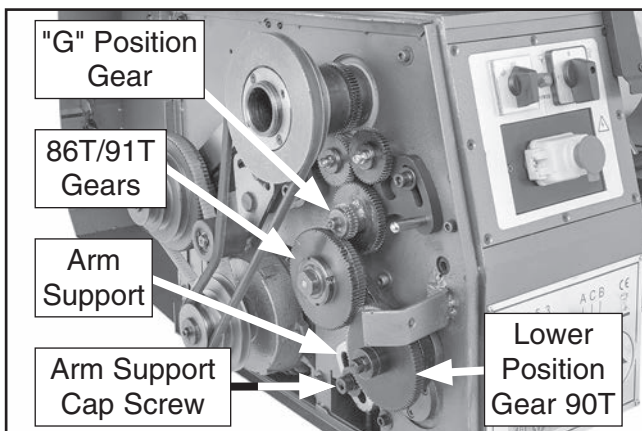

Figure 70. Arm support and end gears.

5. Loosen **86T/91T** gear support shaft and slide middle gear away from lower position gear (see **Figure 71**).

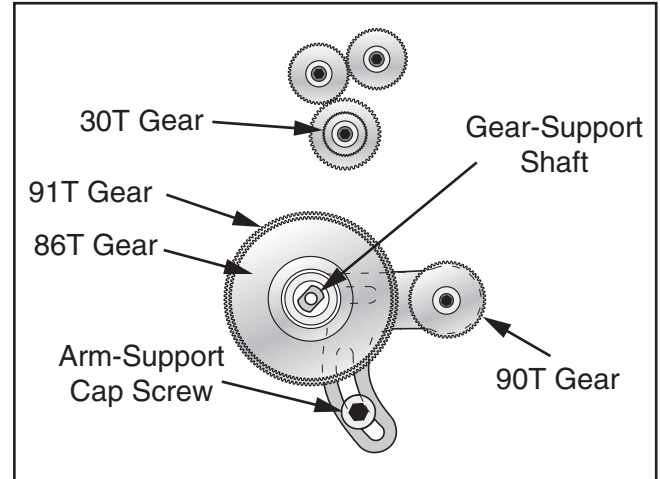

Figure 71. End gear placement.

6. Remove cap screw and flat washer from "G" position, position gear, then slide gears off of shaft.
 7. Slide **30T** gear onto "G" position shaft, making sure to align the key and keyway.
- Note:** Position the flat, non-stepped face of the gear away from the headstock so it will mesh with the 91T gear in **Step 11**.
8. Secure **30T** gear with flat washers and cap screws removed earlier.
 9. Slide **91T** gear against lower **90T** gear (see **Figure 72**) until they mesh with 0.002" to 0.004" backlash, then tighten gear support shaft

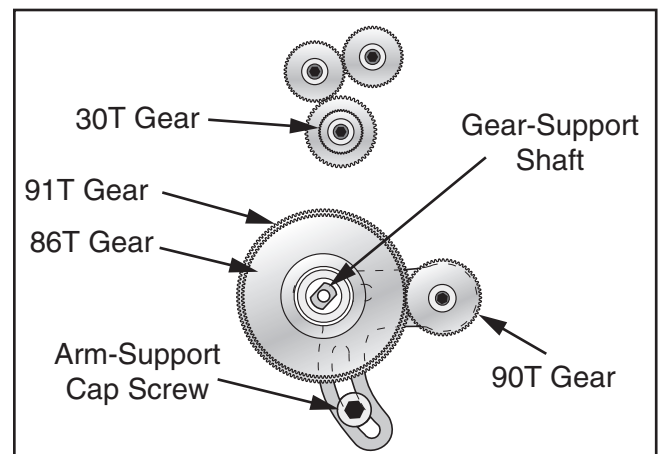

Figure 72. 30T gear installed.



10. Rotate the 91T gear up against the 30T gear until they mesh with 0.002" to 0.004" backlash and re-tighten arm support cap screw (see **Figure 73**).

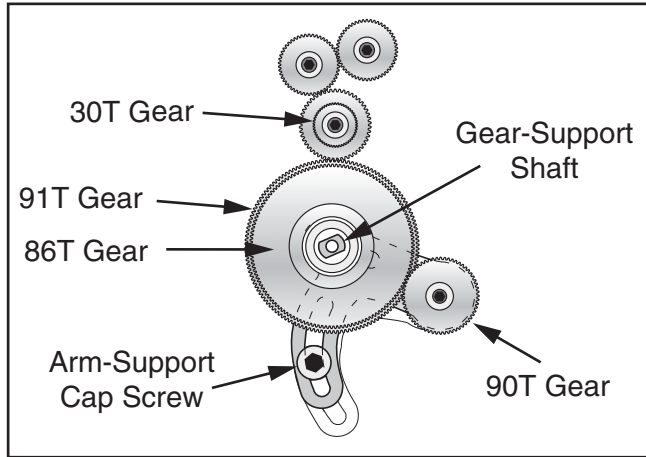

Figure 73. Inch threading gear configuration.

11. Re-install end-gear cover.

Reverse Feed & Threading Configuration

For reverse feeding operations, the upper end-gear arm support (see **Figure 74**) must be repositioned so the 2nd upper end-gear meshes with the spindle gear.

Tools Needed	Qty
Hex Wrench 6mm.....	1

To configure end gears for reverse feed/ reverse threading operations:

1. DISCONNECT LATHE FROM POWER!
2. Open headstock end gear cover.
3. Loosen upper arm support cap screw shown in **Figure 74**.
4. Pivot upper arm-support up so 2nd upper arm gear and spindle gear mesh with 0.002" to 0.004" backlash, then tighten upper arm-support cap screw (see **Figure 75**).

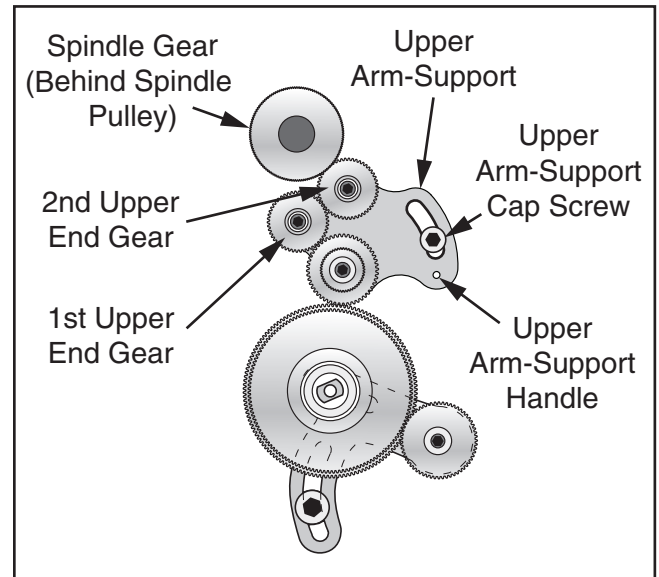

Figure 75. Reverse threading gearing configuration.

5. Re-install end gear cover.

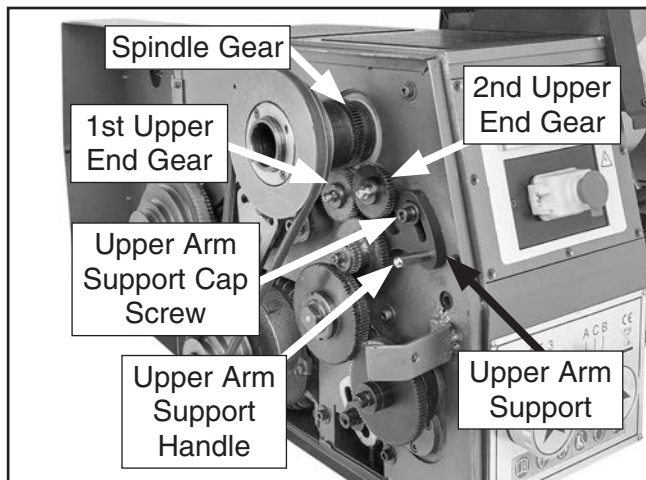

Figure 74. Reverse threading end gear components.



Threading

NOTICE

When threading, use slowest speed possible and avoid deep cuts, so you are able to disengage half nut when required to prevent a carriage crash!

The following subsections will describe how to use the threading controls and charts to set up the lathe for a threading operation. If you are unfamiliar with the process of cutting threads on a lathe, we strongly recommend that you read books, review industry trade magazines, or get formal training before attempting any threading projects.

Headstock Threading Controls

The threading charts on the headstock face display the settings for inch and metric threading.

Using the controls on the lathe, follow the example below to understand how to set up the lathe for the desired threading operation.

To set dials for 72 TPI:

1. Arrange gears in **Primary Threading Configuration**, with 30T gear in "G" position, as explained on **Page 46**.
2. Locate 72 TPI on the inch threading chart below.

		THREADS PER INCH					
G		30			60		
Lever	A	B	C	A	B	C	
1	72	36	18	36	18	9	
2	64	32	16	32	16	8	
3	56	28	14	28	14	7	
4	48	24	12	24	12	6	
5	40	20	10	20	10	5	

Figure 76. 72 TPI and corresponding dial positions.

3. Locate **A** above 72 TPI and find **1** to the left of it.

Note: In the next step, use the chuck key to rock the spindle back-and-forth to help mesh the gears as you make adjustments.

4. Position gearbox dials, as shown in **Figure 77**.

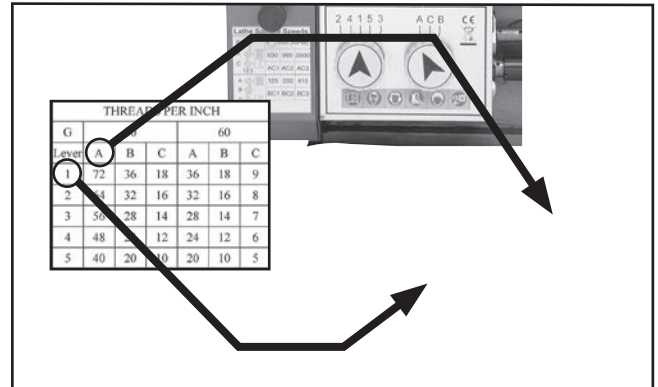

Figure 77. Gearbox dial settings for 72 TPI.

The lathe is now setup to cut 72 TPI threads.

Apron Threading Controls

The half nut lever engages the carriage with the leadscrew, which moves the carriage and cutting tool along the length of the workpiece for threading operations (see **Figure 78**).

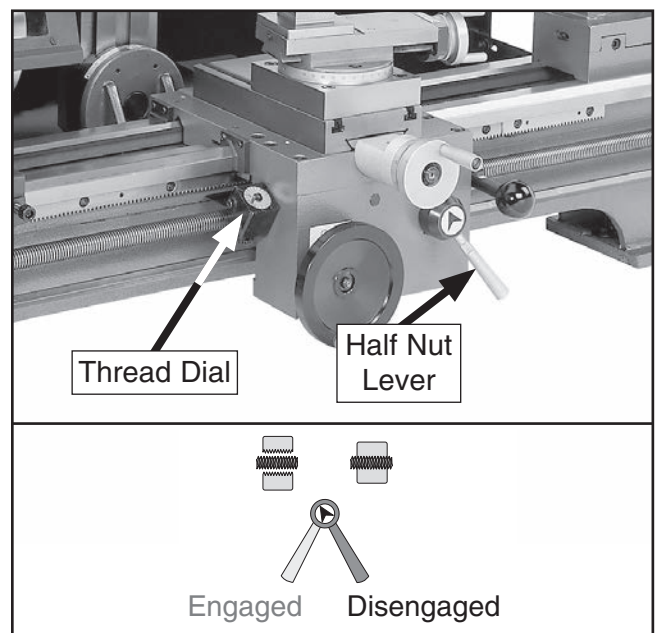

Figure 78. Apron threading controls.



Thread Dial

When the number "0" on the thread dial (**Figure 79**) aligns with the scale mark, this indicates when to engage the half nut during inch threading.

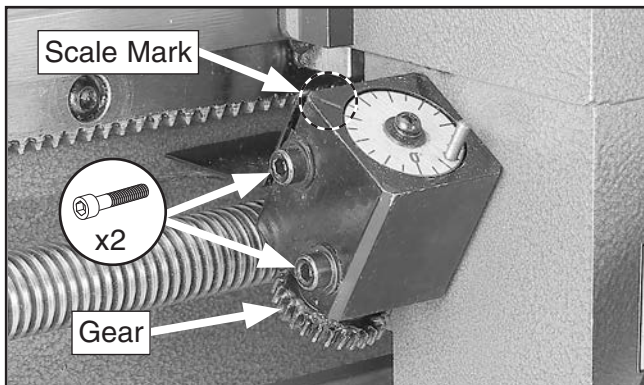

Figure 79. Thread dial details.

Note: The thread dial is not used for metric threading. For that type of operation, you must leave the half nut engaged from the beginning until turning is complete.

When the first cutting pass is complete, the operator disengages the carriage from the leadscrew using the half nut lever. The operator returns the carriage for the next pass and re-engages the half nut using the same thread dial setting to resume the cut in the previous pass.

Thread Dial Gears

The G0773 thread dial comes with a 28T gear installed on the thread dial for cutting standard threads. A 30T gear is also included for cutting some metric threads, but it must be installed in place of the 28T thread dial gear before it can be used (see **Figure 80**).

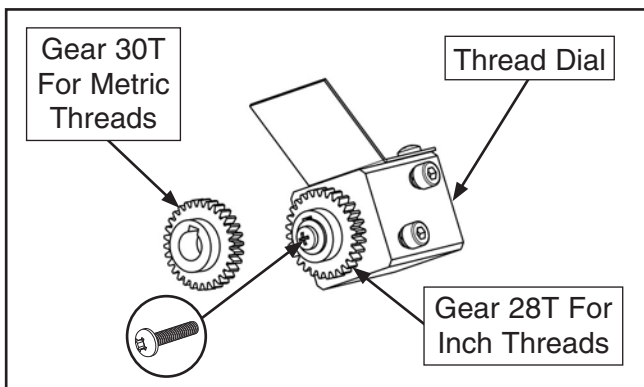

Figure 80. Thread-dial change gears can be exchanged for cutting either inch or metric threads.

To change thread dial gears:

1. Loosen both cap screws shown in **Figure 79** and remove thread dial.
2. Remove Phillips head screw shown in **Figure 80**, remove existing gear from thread dial, and replace with correct gear for threading operation.
3. Replace Phillips head screw and re-install thread dial, making sure teeth of thread dial gear mesh with lead screw.

Thread Dial Chart

To cut standard threads, only use the 28T gear. To cut metric threads, consult the thread dial chart in **Figure 81** to determine which gear to use and when to engage half nut.

Thread Pitch	Gear	Dial Mark
0.25	Z28 or Z30	Any
0.5	Z28 or Z30	Any
1.0	Z28 or Z30	Any
1.25	Z30	0
2.5	Z30	0
0.3	Z28 or Z30	Any
0.6	Z28 or Z30	Any
1.5	Z28 or Z30	Any
0.35	Z28	0
0.7	Z28	0
1.75	Z28	0
0.4	Z28 or Z30	0
0.8	Z28	0
2.0	Z28 or Z30	0

Figure 81. Thread dial chart.



SECTION 5: MILL OPERATIONS

Operation Overview

The purpose of this overview is to provide the novice machine operator with a basic understanding of how the machine is used during operation, so the machine controls/components discussed later in this manual are easier to understand.

Due to the generic nature of this overview, it is **not** intended to be an instructional guide. To learn more about specific operations, read this entire manual and seek additional training from experienced machine operators, and do additional research outside of this manual by reading "how-to" books, trade magazines, or websites.

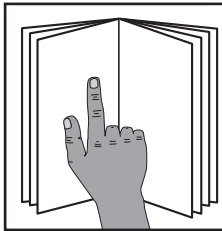

!WARNING

To reduce your risk of serious injury, read this entire manual **BEFORE** using machine.

!WARNING

To reduce risk of eye or face injury from flying chips, always wear approved safety glasses and face shield when operating this machine.

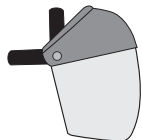

NOTICE

If you are not experienced with this type of machine, **WE STRONGLY RECOMMEND** that you seek additional training outside of this manual. Read books/magazines or get formal training before beginning any projects. Regardless of the content in this section, Grizzly Industrial will not be held liable for accidents caused by lack of training.

!WARNING

To reduce risk of injury and increase longevity of machine, always start spindle rotation with spindle speed dial set to **lowest setting**.

To complete a typical milling operation, the operator does the following:

1. Puts on personal protective equipment.
2. Securely clamps workpiece to cross slide table.
3. With machine disconnected from power, installs correct tooling.
4. Adjusts mill headstock height.
5. Connects machine to power.
6. Rotates spindle speed dial to lowest setting, and resets Emergency Stop button.
7. Presses ON button and rotates spindle speed dial to correct spindle speed.
8. Uses carriage and cross slide controls to perform operation.
9. Presses Emergency Stop button and waits for spindle to completely stop before removing workpiece, changing tooling, or changing spindle speeds.



Removing Compound Rest

The compound rest and tool post must be removed before milling operations so the cross-slide table can be used as the milling table.

Tools Needed	Qty
Hex Wrench 3mm.....	1
Hex Wrench 4mm.....	1

Removing Compound Rest

Remove both cap screws shown in **Figure 82**, then remove compound rest.

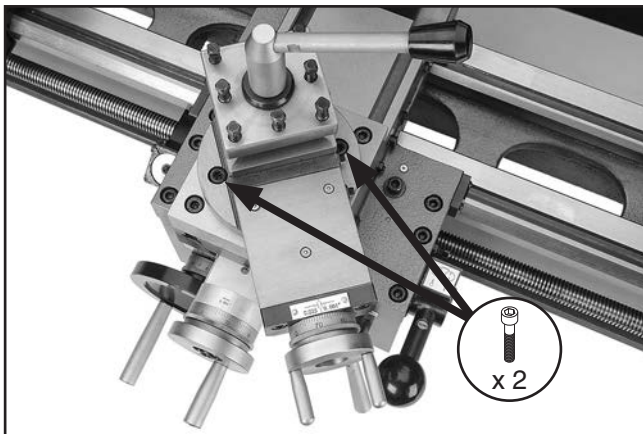

Figure 82. Location of compound rest cap screws.

Re-installing Compound Rest

Align compound rest with swivel base mounting post and M8-1.25 T-nuts (see **Figure 83**), then secure with cap screws previously removed.

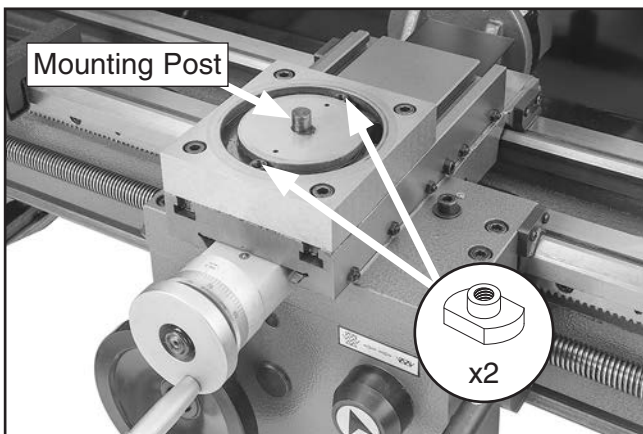

Figure 83. Swivel base components.

Headstock Movement

The milling headstock moves in the following ways:

- Travels up and down the column (Z-axis).
- Tilts 45° left or right relative to the table.

Raising/Lowering Headstock

1. Loosen Z-axis lock lever shown in **Figure 84**.

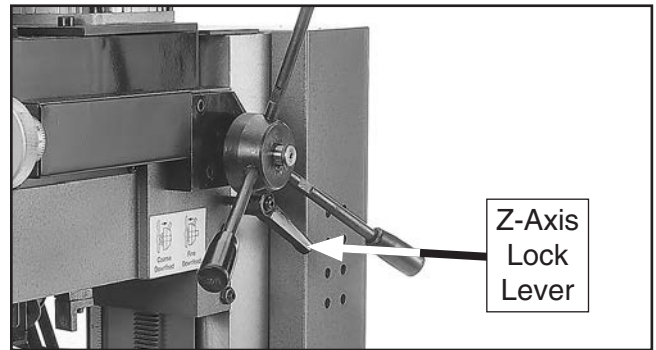

Figure 84. Location of Z-axis lock lever.

2. Use the coarse vertical handwheel shown in **Figure 85** to adjust headstock height and relative position of cutting tool before cutting.

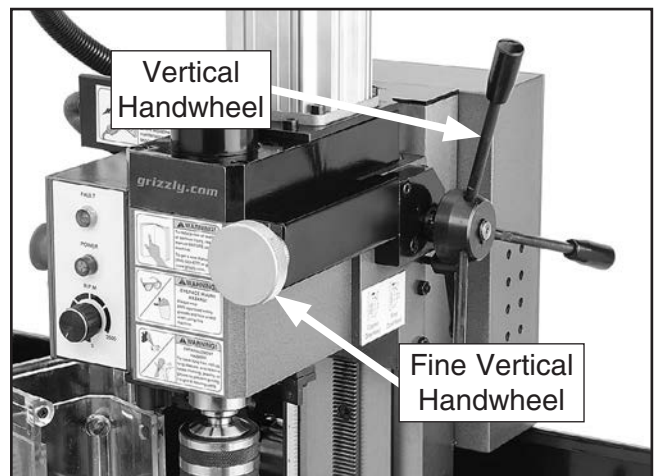

Figure 85. Location of mill headstock vertical controls.

3. Use the fine vertical handwheel shown in **Figure 85** for precision vertical adjustment during milling operations.
4. Retighten lock lever.



Tilting Headstock

Tool Needed	Qty
Wrench 36mm	1

To tilt headstock:

1. DISCONNECT MACHINE FROM POWER!
2. Support headstock with one hand, then loosen headstock center bolt and angle lock nut (see **Figure 86**).

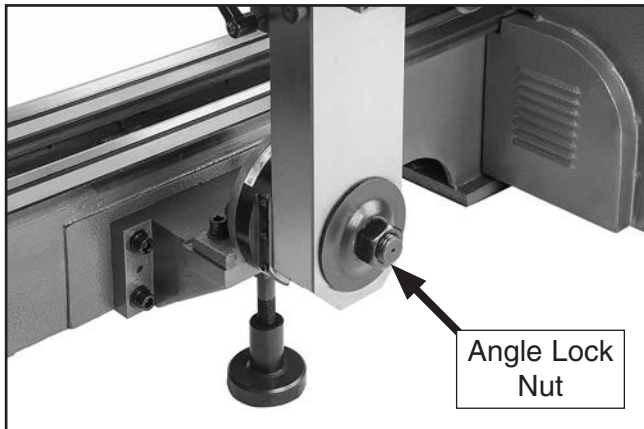

Figure 86. Headstock tilt controls.

3. While viewing tilt scale, rotate headstock to required angle, then retighten center bolt and angle lock nut to secure headstock.

Table Travel

The cross slide table travels in two directions, as illustrated in **Figure 87**:

- X-axis (longitudinal)
- Y-axis (cross)

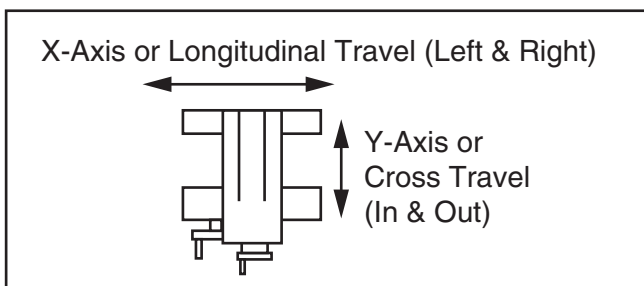

Figure 87. Possible directions of cross slide travel.

These movements are controlled by the carriage handwheel and cross slide handwheel (see **Figure 88**).

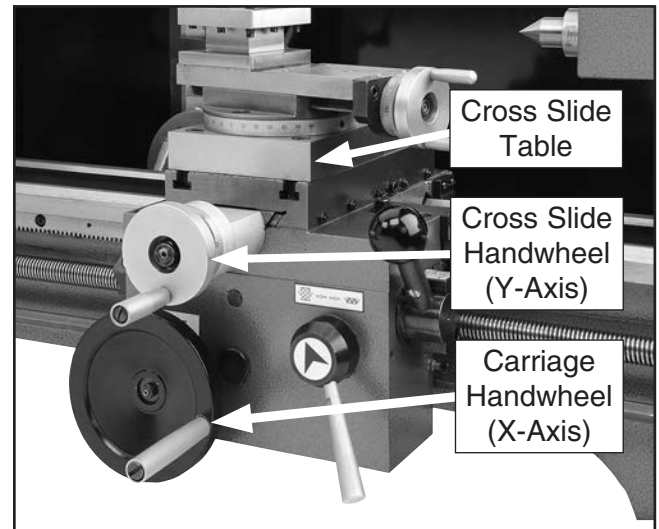

Figure 88. Table travel controls.

Carriage Handwheel (X-Axis)

Graduated Dial

Increments	0.01" (0.25mm)
One Full Revolution	1" (25.4mm)

Use the carriage handwheel to move the carriage left or right along the bed. Adjust the position of the graduated scale by holding the handwheel with one hand and turning the dial with the other.

Cross Slide Handwheel (Y-Axis)

Graduated Dial

Increments	0.001" (0.025mm)
One Full Revolution	0.08" (2.03mm)

Use this handwheel to move the cross slide table toward or away from the tooling. The cross slide handwheel has an indirect-read graduated dial, which shows the actual distance the table moves.



Installing/Removing Tooling



⚠ CAUTION
Cutting tools are sharp and can easily cause cutting injuries. Always protect your hands with leather gloves or shop rags when handling cutting tools.

Installing Tooling

Tools Needed	Qty
Wrench 17mm.....	1
Spindle Locking Pin.....	1

To install tooling:

1. DISCONNECT MACHINE FROM POWER!
2. Remove drawbar cap (see **Figure 89**).

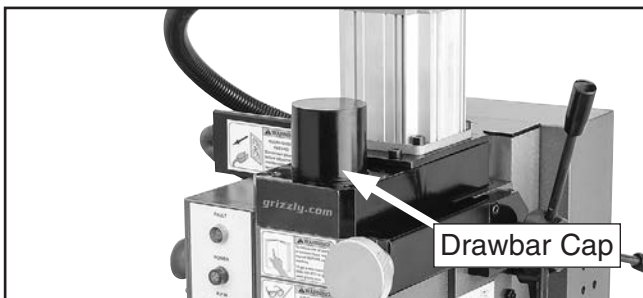

Figure 89. Location of drawbar cap.

3. Insert tooling (not included) into spindle until in contacts drawbar.
4. Working from the top, thread drawbar by hand into tooling until snug (see **Figure 90**).

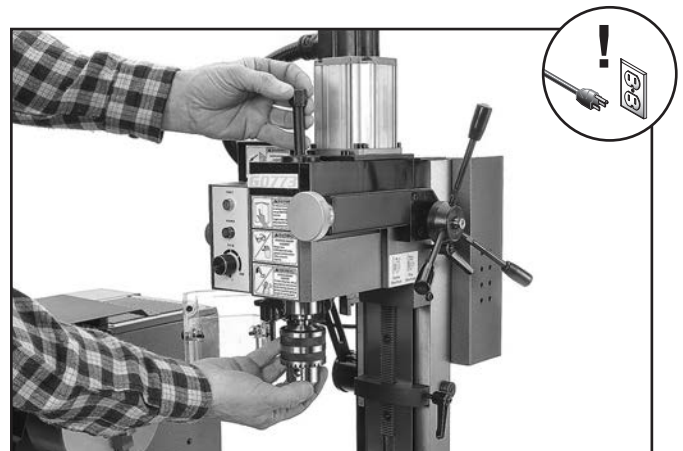

Figure 90. Threading drawbar into tooling.

5. Insert spindle locking pin into hole in spindle, and tighten drawbar, as shown in **Figure 91**.

Note: Do not overtighten drawbar. Overtightening makes tool removal difficult and may damage arbor and threads.

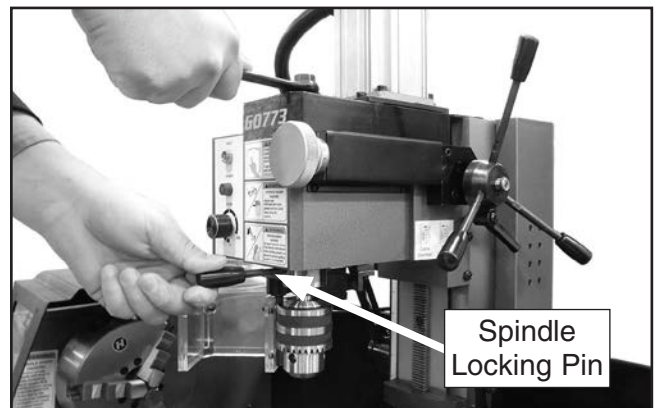

Figure 91. Tightening drawbar lock nut.

6. Re-install drawbar cap.



Removing Tooling

Tools Needed	Qty
Wrench 17mm.....	1
Spindle Locking Pin.....	1
Brass Hammer	1

To remove tooling:

1. DISCONNECT MACHINE FROM POWER!
2. Remove drawbar cap.
3. Insert spindle locking pin into spindle, and loosen drawbar (see **Figure 91** on **Page 54**).
4. Unthread drawbar from tooling one full rotation.

Note: Do not fully unthread tooling from drawbar or the drawbar and tool threads could be damaged in the next step.

5. Tap top of drawbar with hammer to unseat taper (see **Figure 92**).

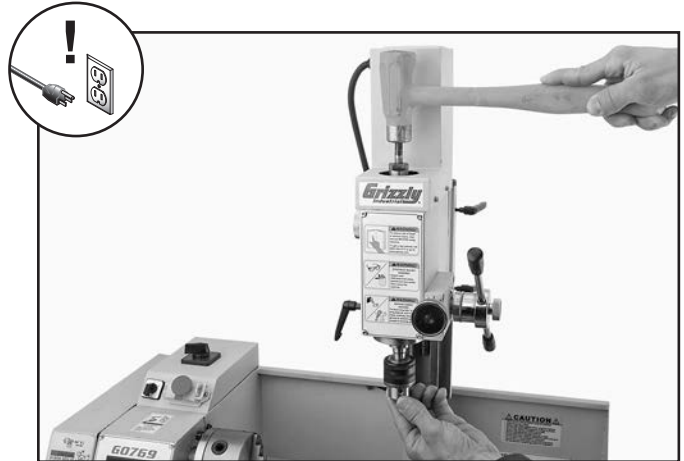

Figure 92. Example of tapping drawbar to unseat tool taper.

6. Hold onto tooling with one hand and fully unthread drawbar with the other hand.



Spindle Speed

Using the correct spindle speed is important for safe and satisfactory results, as well as maximizing tool life.

To set the mill spindle speed for operation, you will need to: 1) Determine the best spindle speed for the cutting/drilling task, and 2) use the spindle speed dial to obtain the spindle speed.

Determining Spindle Speed

Many variables affect the optimum spindle speed to use for any given operation, but the two most important are the recommended cutting speed for the workpiece material and the diameter of the cutting tool, as noted in the formula shown in **Figure 93**.

$\frac{\text{*Recommended Cutting Speed (FPM)} \times 12}{\text{Tool Dia. (in inches)} \times 3.14} = \text{Spindle Speed (RPM)}$ <p>*Double if using carbide cutting tool</p>
--

Figure 93. Spindle speed formula for mill/drills.

Cutting speed, typically defined in feet per minute (FPM), is the speed at which the edge of a tool moves across the material surface.

A recommended cutting speed is an ideal speed for cutting a type of material in order to produce the desired finish and optimize tool life.

The books **Machinery's Handbook** or **Machine Shop Practice**, and some internet sites, provide excellent recommendations for which cutting speeds to use when calculating the spindle speed. These sources also provide a wealth of additional information about the variables that affect cutting speed and they are a good educational resource.

Also, there are a large number of easy-to-use spindle speed calculators that can be found on the internet. These sources will help you take into account the applicable variables in order to determine the best spindle speed for the operation.

Setting Spindle Speed

1. Set Lathe/Mill selector switch to 2 for milling operations (see **Figure 94**).

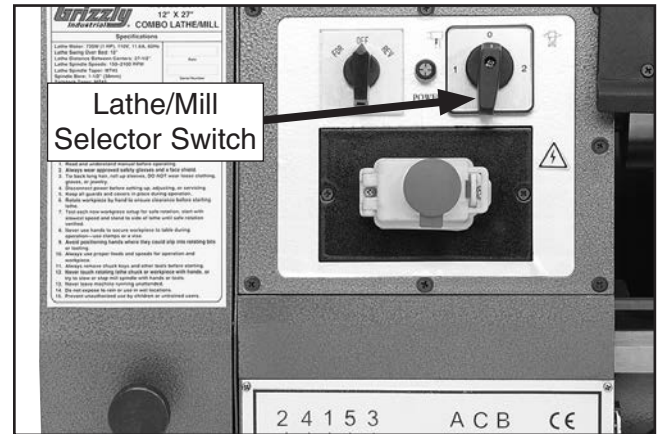

Figure 94. Location of lathe/mill selector switch.

2. Rotate variable-speed dial (see **Figure 95**) clockwise to select mill speed from 100–2500 RPM. Rotate dial further clockwise to increase speed or counterclockwise to decrease speed.

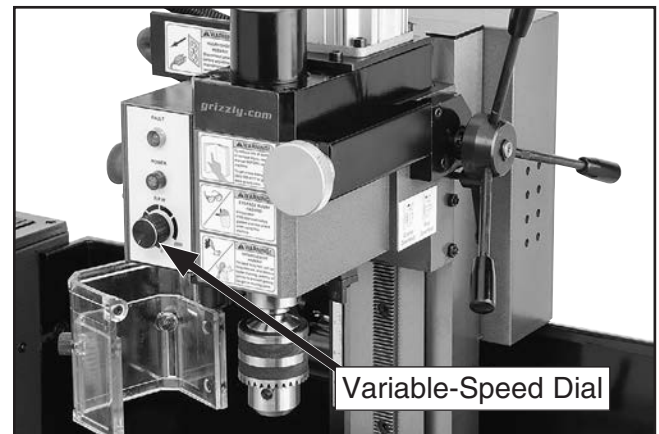

Figure 95. Location of milling head variable-speed dial.



SECTION 6: ACCESSORIES

! WARNING

Installing unapproved accessories may cause machine to malfunction, resulting in serious personal injury or machine damage. To reduce this risk, only install accessories recommended for this machine by Grizzly.

NOTICE

Refer to our website or latest catalog for additional recommended accessories.

T10294—11 Pc. Carbide Bit Set 1/2"

This 1/2" shank, 7-piece turning tool set is ideal for a wide variety of projects. Supplied with right hand and left hand turning/facing tool holders, the set is complimented with one threading and one cut-off tool, too. Indexable inserts ensure cutting surfaces stay sharp.



Figure 96. Model T10294 7-Pc. carbide-tipped tool set.

- H2987—1/2" Bent Lathe Dog
- H2988—1" Bent Lathe Dog
- H2989—1 1/2" Bent Lathe Dog
- H2990—2" Bent Lathe Dog
- H2991—3" Bent Lathe Dog



Figure 97. Model H2990 1/2" Bent Lathe Dog.

SB1365—South Bend Lathe Way Oil, 12 oz.

T23962—ISO 68 Moly-D Way Oil, 5 gal.

T23963—ISO 32 Moly-D Machine Oil, 5 gal.

T23964—Moly-D NLGI#2 Grease.

Moly-D oils are some of the best we've found for maintaining the critical components of machinery because they tend to resist run-off and maintain their lubricity under a variety of conditions—as well as reduce chatter or slip. Buy in bulk and save with 5-gallon quantities.



Figure 98. 12 oz. way oil & 5 gallon machine oil.

order online at www.grizzly.com or call 1-800-523-4777



G1070—MT3 Live Center Set

A super blend of quality and convenience, this live center set offers seven interchangeable tips. High-quality needle bearings prolong tool life and special tool steel body and tips are precision ground. Supplied in wooden box.



Figure 99. G1070 Live Center Set.

H5930—4-Pc. Center Drill Set 60°

H5931—4-Pc. Center Drill Set 82°

Double-ended HSS Center Drills are precision ground. Each set includes sizes 1–4.

SIZE	BODY DIA.	DRILL DIA.	OVERALL LENGTH
1	1/8"	3/64"	1 1/4"
2	3/16"	5/64"	1 7/8"
3	1/4"	7/64"	2"
4	5/16"	1/8"	2 1/8"

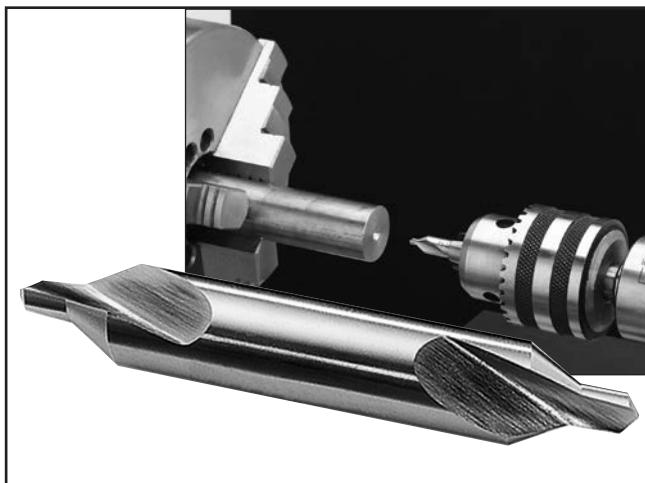

Figure 100. HSS ground center-drill sets.

H6202—1/2" x JT3 High-Precision Drill Chuck

H6204—5/8" x JT3 High-Precision Drill Chuck

G1675—Drill Chuck Arbor - R-8/JT3

G1677—Drill Chuck Arbor - MT3/JT3

Unlike most keyed drill chucks, Models H6202 and H6204 are made to very tight tolerances on CNC equipment and are some of the finest drill chucks on the market today. They have very high gripping strength and are suitable for heavy-duty, high speed drilling. Each chuck includes a high visibility chuck key. Drill chuck arbors are used to adapt drill chucks to your milling machine or lathe.

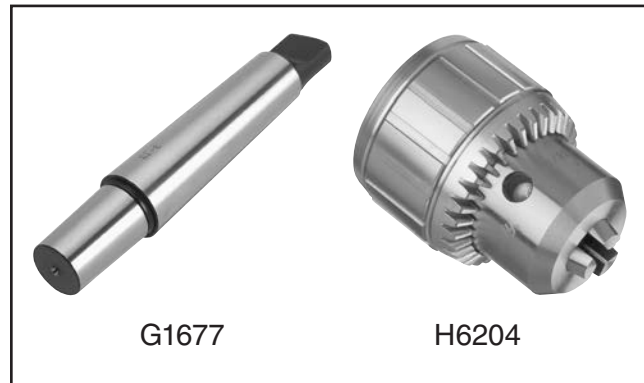

Figure 101. High-precision drill chuck and drill chuck arbor.

G9788—4-Pc. Measuring Tool Set

This is the set you need for accurate measurements. Includes a stainless steel 6" dial caliper, a 6" scale with inch scale on one side and a metric scale on the other, a 1" carbide-tipped micrometer with vernier scale, and a 4" precision square with beveled edge. Comes with molded case and micrometer adjustment wrench.



Figure 102. Model G9788 4-Pc. Measuring Tool Set.

order online at www.grizzly.com or call 1-800-523-4777



T10253—2" Mini Self-Centering Swivel Vise

T10254—2" Mini Self-Centering Vise

Ideal for holding small parts and model making. Both models feature self-centering jaws, adjustable gib on a dovetailed way, 2¹/₁₆" jaw opening, and 2" jaw width. T10253 base swivels 360°, and overall size is 6³/₄" L x 4" W x 3³/₈" H with handle removed. T10254 overall size is 6¹/₂" L x 3¹/₂" W x 2³/₈" H with handle removed.

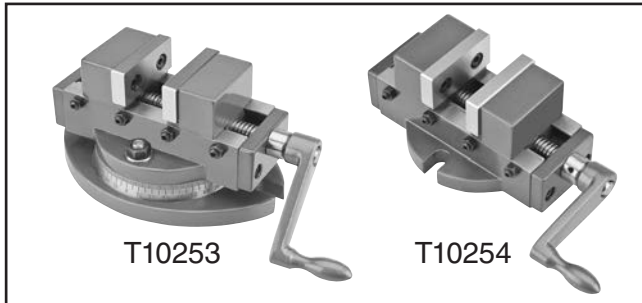

Figure 103. Mini Self-Centering Visers.

4-Flute C-2 Grade Carbide End Mills

These American-made 4-flute Carbide End Mills feature standard cutting lengths and nominal minus diameter tolerances. Recommended for profiling and finishing non-ferrous materials.

Model	Cutting Diameter	Flute Length	OA Length
H3649	1/16"	3/16"	1 1/2"
H3650	3/32"	3/8"	1 1/2"
H3651	1/8"	1/2"	1 1/2"
H3652	5/32"	9/16"	2"
H3653	3/16"	5/8"	2"
H3654	7/32"	5/8"	2 1/2"
H3655	1/4"	3/4"	2 1/2"
H3656	9/32"	3/4"	2 1/2"
H3657	5/16"	13/16"	2 1/2"
H3658	3/8"	7/8"	2 1/2"
H3659	7/16"	1"	2 3/4"
H3660	1/2"	1"	3"

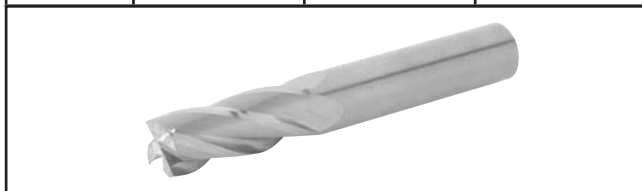

Figure 104. 4-Flute C-2 grade carbide end mills.

H6195—3" Rotary Table w/ Clamps

For horizontal or vertical use. 3" diameter table rotates 360°. Low profile—only 1.670" tall. 4⁵/₁₆" T-slots. 1:36 ratio or 10° per handwheel revolution. Scale reads to 15 minutes. Has brass lock knob. Table height in horizontal position: 1⁵/₈"; in vertical position: 3/4".

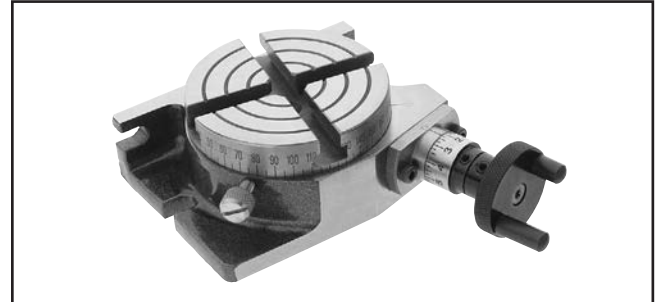

Figure 105. Model H6195 3" Rotary Table w/ Clamps.

R-8 End Mill Holders

Hold your end mills in the Model G0773 spindle with these quality end mill holders. Sized for various end mill shanks.

Model	Taper	Size
T25697	R-8	3/16"
T25698	R-8	3/8"
T25699	R-8	1/2"
T25700	R-8	5/8"
T25701	R-8	3/4"



Figure 106. R-8 end mill holders.

order online at www.grizzly.com or call 1-800-523-4777



G9274—6" Stainless Steel Outside Calipers
G9275—8" Stainless Steel Outside Calipers
G9276—10" Stainless Steel Outside Calipers
G9277—12" Stainless Steel Outside Calipers
G9278—16" Stainless Steel Outside Calipers

Spring Calipers with quick adjustment nut provide fast determination of external measurements. Ideal for physically transferring dimensions from originals. Five different sizes allow you to match the best caliper for your shop needs.

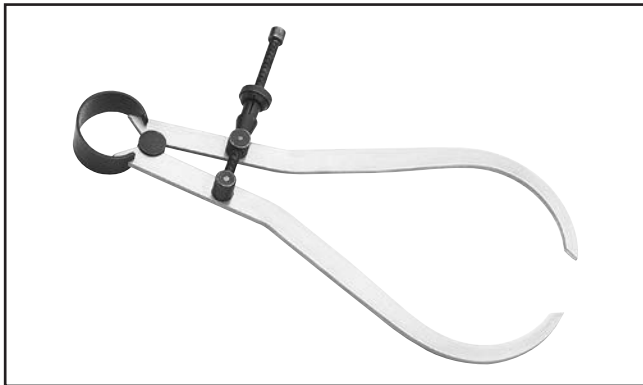

Figure 107. G9274 16" Stainless Steel Calipers.

T10255—Mini Lathe Tool Kit

Includes right, left, and straight turning tool holders with 1/8" HSS tool bits, boring bar with holder and 1/8" HSS tool bit, cut off tool holder with 3/32" HSS blade and 3/8" shank, mini cut off tool holder with 1/16" HSS blade and 5/16" shank, knurling tool holder with pivoting head, single horizontal/vertical knurling tool holder and assorted hex wrenches. Maximum shank size is 1/2".

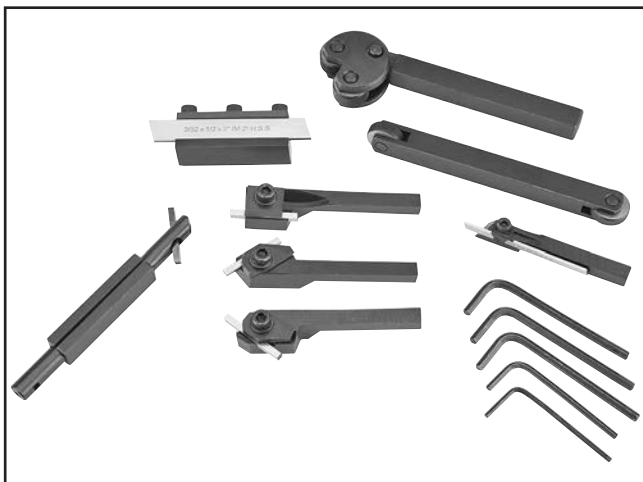

Figure 108. T10255 Mini Lathe Tool Kit.

H7616—Oil Can w/Plastic Nozzle

This high-pressure oil can is perfect for lubricating the ball oilers found on your machine. Each can holds 5 ounces of oil.



Figure 109. High-pressure oil can for ball oilers.

H6879—Lathe Operation & Maintenance Book

This detailed metal lathe book provides extensive coverage of a wide variety of metalworking operations. Special emphasis is placed on lathe components, accessories, and operating procedures, including basic machine setup and routine maintenance. A "must have" reference for all metal lathe owners. 260 pages.

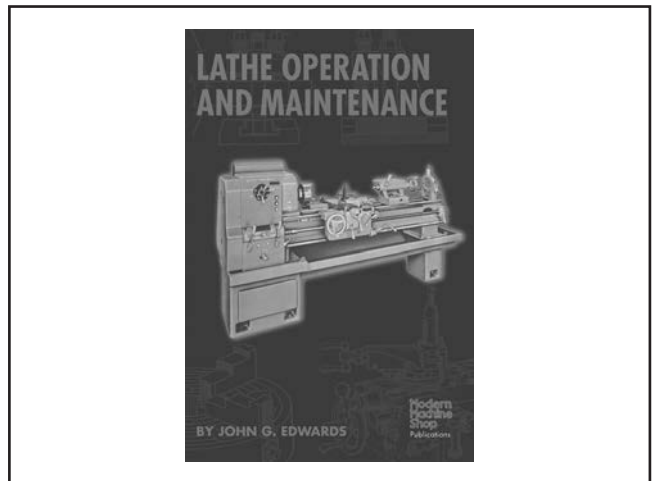
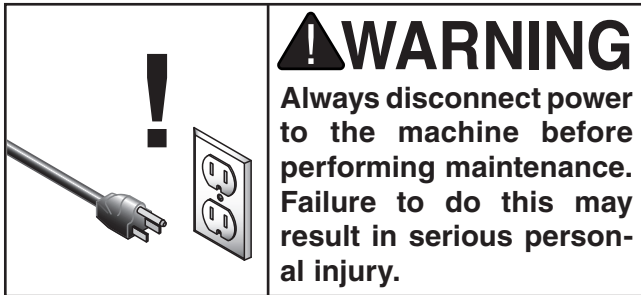

Figure 110. H6879 Lathe Operation & Maintenance Book.



SECTION 7: MAINTENANCE



Schedule

Ongoing

To maintain a low risk of injury and proper machine operation, if you ever observe any of the items below, shut down the machine immediately and fix the problem before continuing operations:

- Loose mounting bolts or fasteners.
- Worn, frayed, cracked, or damaged wires.
- Guards or covers removed.
- Emergency Stop button not working correctly or not requiring you to reset it before starting the machine again.
- Damaged or malfunctioning components.

Daily, Before Operations

- Add oil to the ball oilers (**Page 62**).
- Lubricate the leadscrew and carriage rack (**Page 63**).
- Lubricate the bedways (**Page 63**).
- Clean/lubricate the cross slide and compound slide (**Page 63**).
- Disengage the half nut on the carriage (to prevent crashes upon startup).
- Lubricate column ways (**Page 66**).

Daily, After Operations

- Press the Emergency Stop button (to prevent accidental startup).
- Vacuum/clean all chips and swarf from bed, slides.
- Wipe down all unpainted or machined surfaces with an oiled rag.

Annually

- Lubricate end gears (**Page 65**).

Cleaning/Protecting

Because of its importance, we recommend that the cleaning routine be planned into the workflow schedule.

Typically, the easiest way to clean swarf from the machine is to use a brush and wet/dry shop vacuum that are dedicated for this purpose. The small chips left over after vacuuming can be wiped up with a slightly oiled rag. Avoid using compressed air to blow off chips, as this may drive them deeper into the moving surfaces or cause sharp chips to fly into your face or hands.

All unpainted and machined surfaces should be wiped down daily to keep them rust free and in top condition. This includes any surface that is vulnerable to rust if left unprotected. Use a quality ISO 68 way oil (see **Page 57** for offerings from Grizzly) to prevent corrosion.



Lubrication

The lathe has metal-to-metal sliding surfaces that require regular lubrication to maintain smooth movement and ensure long-lasting precision.

Other than the lubrication points covered in this section, all other bearings are internally lubricated and sealed at the factory. Simply leave them alone unless they need to be replaced.

Before performing any lubrication task, DISCONNECT MACHINE FROM POWER!

We recommend using Model SB1365 Way Oil, T23963 Machine Oil, and T23964 Multi-Purpose Grease or equivalents (see **Page 57**) for most lubrication tasks.

Lubrication Frequency

Lubrication Task	Frequency	Page
Ball Oilers	Daily	This Page
Leadscrew & Carriage Rack	Daily	63
Bedways	Daily	63
Feed Gearbox	Annually	64
Cross Slide & Compound Slide	Daily	64
End Gears	Annually	65
Mill Column Ways	Daily	66

NOTICE

The recommended lubrication is based on light-to-medium usage. Since lubrication helps to protect value and operation of machine, these lubrication tasks may need to be performed more frequently than recommended, depending on usage.

Failure to follow reasonable lubrication practices as instructed in this manual could lead to premature failure of machine components and will void the warranty.

Items Needed

	Qty
Clean Rags.....	As Needed
Mineral Spirits.....	As Needed
Stiff Brush.....	1
Pump-Type Oil Can w/Plastic Cone Tip	1

Ball Oilers

Lube Type.....	ISO 32 Equivalent
Lube Amount	1 or 2 Squirts/Fill
Lubrication Frequency.....	Daily

This lathe has four ball oilers that should be oiled on a daily basis before beginning operation.

Proper lubrication of ball oilers is done with a pump-type oil can that has a plastic or rubberized cone tip. We do not recommend using metal needle or lance tips, as they can push the ball too far into the oiler, break the spring seat, and lodge the ball in the oil galley.

Lubricate the ball oilers before and after machine use, and more frequently under heavy use. When lubricating ball oilers, first clean the outside surface to remove any dust or grime. Push the tip of the oil can nozzle against the ball oiler to create a hydraulic seal, then pump the oil can once or twice. If you see sludge and contaminants coming out of the lubrication area, keep pumping the oil can until the oil runs clear. When finished, wipe away any excess oil.



Refer to **Figures 111–113** to find the location of each ball oiler.



Figure 111. Apron ball oilers.

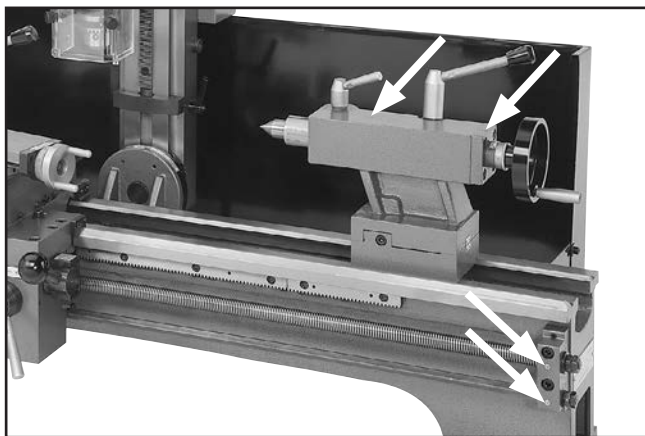

Figure 112. Tailstock and leadscrew end ball oilers.

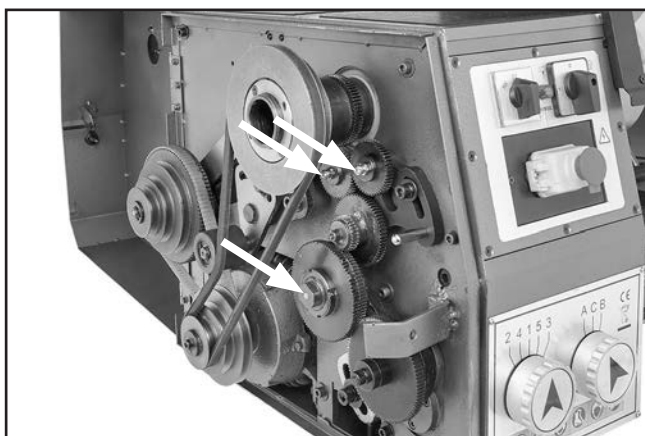

Figure 113. End gear ball oilers.

Leadscrew & Carriage Rack

Lube Type.. Model SB1365 or ISO 68 Equivalent
 Lube Amount As Needed
 Lubrication Frequency Daily

Before lubricating the leadscrew and carriage rack (see **Figure 114**), clean them first with mineral spirits. Use a stiff brush to help remove any debris or grime. Apply a thin coat of oil along the entire length of the carriage rack. Use a stiff brush to make sure oil is applied into the leadscrew threads.

Note: *In some environments, abrasive material can become caught in the leadscrew lubricant and drawn into the half nut. In this case, lubricate the leadscrew with a quality dry lubricant.*

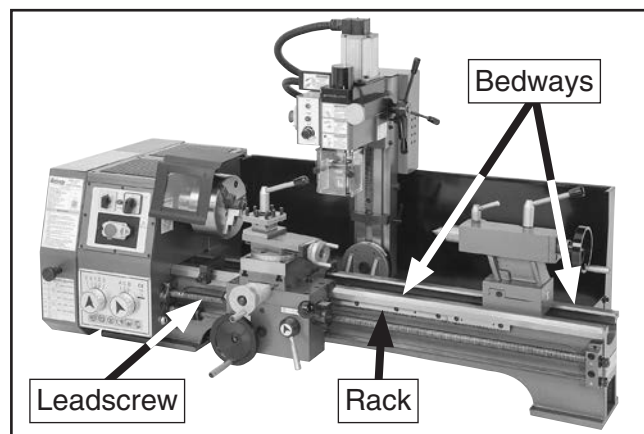

Figure 114. Identification of leadscrew, rack, and bedways for lubrication.

Bedways

Lube Type.. Model SB1365 or ISO 68 Equivalent
 Lube Amount As Needed
 Lubrication Frequency Daily

Before lubricating the bedways (see **Figure 114**), clean them with mineral spirits. Apply a thin coat of oil along the length of the bedways. Move the steady rest, carriage, and tailstock to access the entire length of the bedways.



Feed Gearbox

Oil Type Grizzly T23963 or ISO 32 Equivalent
Oil Amount..... 1 Quart
Check/Add Frequency..... Daily
Change Frequency..... Annually

Checking Oil Level

The gearbox reservoir has the proper amount of oil when the oil level in the sight glass is approximately halfway. The oil sight glass is located on the front of the gearbox, as shown in **Figure 115**.

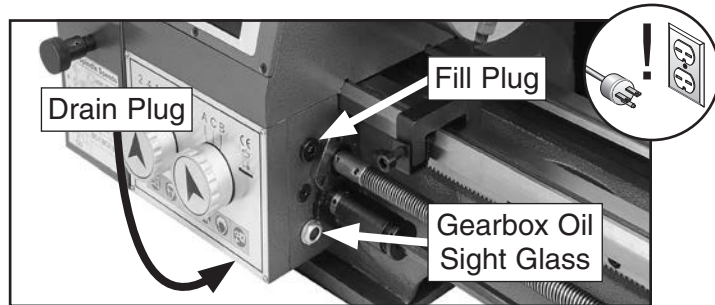

Figure 115. Location of quick-change oil sight glass and fill plug.

Changing Oil

Place a catch pan under the quick-change gearbox drain plug (see **Figure 115**). Use an 8mm hex wrench to remove the gearbox fill plug, then remove the drain plug and allow the gearbox reservoir to empty. Re-install the drain plug and add oil until the level is approximately halfway in the gearbox oil sight glass, then re-install the fill plug.

Cross Slide & Compound Slide

Lube Type.. Model SB1365 or ISO 68 Equivalent
Lube Amount.....Thin Coat
Lubrication Frequency..... Daily

Use the handwheels to separately move the cross slide and compound rest as far forward as possible (see **Figure 116**). Clean the slides with mineral spirits and wipe down with a rag. Apply lubricant and move the slides back and forth to distribute the oil.

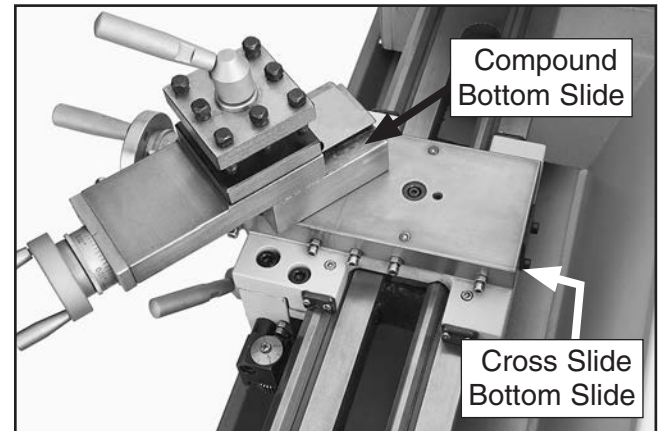

Figure 116. Example of bottom slides.



End Gears

Lube Type..Model T23964 or NLGI#2 Equivalent
Frequency..... Annually or When Changing

The end gears, shown in **Figure 117**, should always have a thin coat of heavy grease to minimize corrosion, noise, and wear. Wipe away excess grease that could be thrown onto the V-belts and reduce optimal power transmission from the motor.

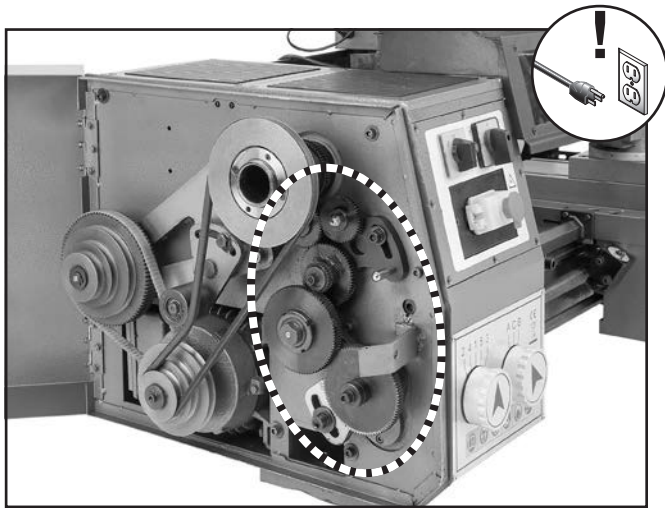

Figure 117. End gears.

Handling & Care

Make sure to clean and lubricate any gears you install or change. Be very careful during handling and storage—the grease coating on the gears will easily pickup dirt or debris, which can then spread to the other gears and increase the rate of wear.

Make sure the end cover remains installed whenever possible to keep the gears free of dust or debris from the outside environment.

Lubricating

1. DISCONNECT MACHINE FROM POWER!
2. Remove end gear cover and all end gears shown in **Figure 117**.
3. Clean end gears thoroughly with mineral spirits to remove old grease. Use a small brush if necessary to clean between teeth.
4. Clean shafts, and wipe away any grease splatters in vicinity and on inside of end cover.
5. Using a clean brush, apply a thin layer of white lithium grease on the gears. Make sure to get grease between gear teeth, but do not fill teeth valleys.
6. Apply a small dab of grease to each gear shaft.
7. Install end gears and mesh them together with an approximate 0.002"–0.004" backlash. Once gears are meshed together, apply a small dab of grease between them where they mesh together—this grease will be distributed when gears rotate and re-coat any areas scraped off during installation.
8. Re-install end cover before re-connecting machine to power.



Column Rack

Lube Type.. Model SB1365 or ISO 68 Equivalent
Lube AmountThin Coat
Lubrication Frequency Daily

Regular lubrication will ensure your milling head-stock performs at its highest potential. Regularly wipe table and column rack with recommended lubrication, then move components back and forth several times to ensure smooth movements (see **Figure 118**).

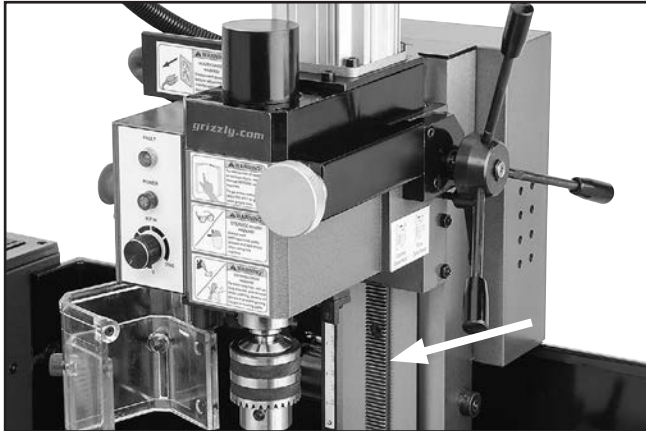

Figure 118. Column Rack lubrication location.

Machine Storage

To prevent the development of rust and corrosion, the lathe must be properly prepared if it will be stored for a long period of time. Doing this will ensure the lathe remains in good condition for later use.

Preparing Machine for Storage

1. DISCONNECT MACHINE FROM POWER!
2. Thoroughly clean all unpainted, bare metal surfaces, then apply a liberal coat of way oil, heavy grease, or rust preventative. Take care to ensure these surfaces are completely covered and that rust preventative or grease is kept off of painted surfaces.
3. Lubricate machine as outlined in lubrication section. Be sure to use an oil can to purge all ball oilers and oil passages with fresh oil.
4. Place a few moisture absorbing desiccant packs inside electrical box.
5. Cover machine and place it in a dry area that is out of direct sunlight and away from hazardous fumes, paint, solvents, or gas. Fumes and sunlight can bleach or discolor paint.
6. Every few months, rotate by hand all gear-driven components a few times in several gear selections. This will keep bearings, bushings, gears, and shafts well lubricated and protected from corrosion—especially during winter months.

Slide carriage, tailstock, and steady rest down lathe bed to make sure that way spotting is not beginning to occur. Move mill headstock up and down column.

Bringing Machine Out of Storage

1. Remove moisture-absorbing desiccant packs from electrical box.
2. Repeat **Test Run** and **Spindle Break-In** procedures, beginning on **Page 24**.



SECTION 8: SERVICE

Review the troubleshooting and procedures in this section if a problem develops with your machine. If you need replacement parts or additional help with a procedure, call our Technical Support at (570) 546-9663.

Note: Please gather the serial number and manufacture date of your machine before calling.

Troubleshooting



Motor & Electrical

Symptom	Possible Cause	Possible Solution
Machine does not start or a circuit breaker trips.	<ol style="list-style-type: none"> 1. Improper switch position at startup. 2. Incorrect power supply voltage. 3. Power supply circuit breaker tripped or fuse blown. 4. Wiring open/has high resistance. 5. On/Off switch at fault. 6. Emergency stop button engaged or at fault. 7. Spindle speed dial at fault. 8. Spindle direction switch at fault. 9. Lathe/mill selector switch at fault. 10. Spindle rotation switch at fault. 11. Motor at fault. 	<ol style="list-style-type: none"> 1. DISCONNECT MACHINE FROM POWER; follow proper procedure for startup (see Page 24). 2. Ensure correct power supply voltage. 3. Ensure circuit is sized correctly and free of shorts. Reset circuit breaker or replace fuse. 4. Check/fix broken, disconnected, or corroded wires. 5. Test/replace switch. 6. Test/replace Emergency Stop button. 7. Test/replace dial. 8. Test/replace switch. 9. Test/replace switch. 10. Test/replace switch. 11. Test/repair/replace.
Machine stalls or is underpowered.	<ol style="list-style-type: none"> 1. Machine undersized for task. 2. Belts slipping or contaminated with oil or grease. 3. Wrong workpiece material. 4. Feed rate/cutting speed too fast. 5. Motor overheated. 6. Computer board at fault. 7. Motor speed dial at fault. 8. Pulley/sprocket slipping on shaft. 9. Motor bearings at fault. 10. Motor at fault. 	<ol style="list-style-type: none"> 1. Use sharp bits/chisels at correct angle; reduce feed rate/depth of cut; use coolant if possible. 2. Tension/replace belts; ensure belts and pulleys are clean and dry. 3. Use correct type/size of metal. 4. Decrease feed rate/cutting speed. 5. Use sharp bits; reduce feed rate/depth of cut. 6. Clean motor, let cool, and reduce workload. 7. Test and replace if at fault. 8. Replace loose pulley/shaft. 9. Test by rotating shaft; rotational grinding/loose shaft requires bearing replacement. 10. Test/repair/replace.
Machine has vibration or noisy operation.	<ol style="list-style-type: none"> 1. Motor or component loose. 2. Bit chattering. 3. V-belt(s) worn or loose. 4. Motor fan rubbing on fan cover. 5. Motor mount loose/broken. 	<ol style="list-style-type: none"> 1. Inspect/replace damaged bolts/nuts, and retighten with thread locking fluid. 2. Replace/sharpen bit; index bit to workpiece; use correct feed rate and cutting RPM; retract tool holder and position workpiece closer. 3. Inspect/replace belts with a new matched set. 4. Fix/replace fan cover; replace loose/damaged fan. 5. Tighten/replace.



Lathe Operation

Symptom	Possible Cause	Possible Solution
Bad surface finish.	<ol style="list-style-type: none"> 1. Wrong spindle speed or feed rate. 2. Dull tooling or poor tool selection. 3. Tool height not at spindle centerline. 4. Too much play in gibs. 	<ol style="list-style-type: none"> 1. Adjust for appropriate spindle speed and feed rate. 2. Sharpen tooling or select a better tool for the intended operation. 3. Adjust tool height to spindle centerline (see Page 39). 4. Tighten gibs (see Page 72).
Tapered tool difficult to remove from tailstock quill.	<ol style="list-style-type: none"> 1. Quill not fully retracted into tailstock. 2. Contaminants not removed from taper before inserting into quill. 	<ol style="list-style-type: none"> 1. Turn quill handwheel until tapered tool is forced out of quill. 2. Clean taper and bore, then re-install tool.
Cross slide, compound rest, or carriage feed has sloppy operation.	<ol style="list-style-type: none"> 1. Ways loaded with shavings, dust, or grime. 2. Gibs are out of adjustment. 3. Handwheel loose or excessive backlash. 4. Leadscrew mechanism worn or out of adjustment. 	<ol style="list-style-type: none"> 1. Clean ways and relubricate. 2. Adjust gibs (see Page 72). 3. Tighten handwheel fasteners, adjust handwheel backlash to a minimum (see Page 71). 4. Adjust leadscrew to remove end play (see Page 71).
Cross slide, compound, or carriage handwheels hard to move.	<ol style="list-style-type: none"> 1. Ways loaded with chips, dust, or grime. 2. Gibs are too tight. 3. Backlash setting too tight. 4. Bedways are dry. 5. Half nut lever engaged. 	<ol style="list-style-type: none"> 1. Clean ways and lubricate. 2. Loosen gibs slightly (see Page 72). 3. Slightly loosen backlash setting (see Page 71). 4. Lubricate bedways. 5. Disengage half nut lever for manual feeding.
Cutting tool or machine components vibrate excessively during cutting.	<ol style="list-style-type: none"> 1. Tool holder not tight enough. 2. Cutting tool sticks too far out of tool holder; lack of support. 3. Gibs are out of adjustment. 4. Dull cutting tool. 5. Incorrect spindle speed or feed rate. 	<ol style="list-style-type: none"> 1. Check for debris, clean, and retighten. 2. Re-install cutting tool so no more than $\frac{1}{3}$ of the total length is sticking out of tool holder. 3. Adjust gibs at affected component (see Page 72). 4. Replace or resharpen cutting tool. 5. Use the recommended spindle speed and feed rate.
Workpiece is tapered.	<ol style="list-style-type: none"> 1. Headstock and tailstock not properly aligned. 	<ol style="list-style-type: none"> 1. Re-align tailstock to headstock spindle centerline (see Page 34).
Chuck jaws will not move or do not move easily.	<ol style="list-style-type: none"> 1. Chips lodged in jaws or scroll plate. 	<ol style="list-style-type: none"> 1. Remove jaws, clean and lubricate scroll plate, then replace jaws.



Mill Operation

Symptom	Possible Cause	Possible Solution
Tool slips in spindle.	<ol style="list-style-type: none"> 1. Tool is not fully drawn up into spindle taper. 2. Debris on tool or in spindle taper. 3. Taking too big of cut. 	<ol style="list-style-type: none"> 1. Tighten drawbar (Do not overtighten). 2. Clean collet and spindle taper. 3. Lessen depth of cut and allow chips to clear.
Breaking tools or cutters.	<ol style="list-style-type: none"> 1. Spindle speed/feed rate is too fast. 2. Cutting tool too small. 3. Cutting tool getting too hot. 4. Taking too big of a cut. 5. Spindle extended too far down. 	<ol style="list-style-type: none"> 1. Set spindle speed correctly (Page 56) or use slower feed rate. 2. Use larger cutting tool and slower feed rate. 3. Use coolant fluid or oil for appropriate application if possible. 4. Lessen depth of cut and allow chips to clear. 5. Fully retract spindle and lower headstock. This increases rigidity.
Workpiece vibrates or chatters during operation.	<ol style="list-style-type: none"> 1. Workpiece not secure. 2. Spindle speed/feed rate is too fast. 3. Spindle extended too far down. 	<ol style="list-style-type: none"> 1. Properly clamp workpiece on table or in vise. 2. Set spindle speed correctly (Page 56) or use slower feed rate. 3. Fully retract spindle and lower headstock. This increases rigidity.
Cross slide table is hard to move.	<ol style="list-style-type: none"> 1. Chips have loaded up on ways. 2. Ways are dry and need lubrication. 3. Gibs are too tight. 	<ol style="list-style-type: none"> 1. Frequently clean away chips that load up during milling operations. 2. Lubricate ways (Page 64). 3. Adjust gibs (see Page 72).
Bad surface finish.	<ol style="list-style-type: none"> 1. Spindle speed/feed rate is too fast. 2. Using dull or incorrect cutting tool. 3. Wrong rotation of cutting tool. 4. Workpiece not secure. 5. Spindle extended too far down. 	<ol style="list-style-type: none"> 1. Set spindle speed correctly (Page 56) or use a slower feed rate. 2. Sharpen cutting tool or select one that better suits operation. 3. Check for proper cutting rotation for cutting tool. 4. Properly clamp workpiece on table or in vise. 5. Fully retract spindle and lower headstock. This increases rigidity.



Tensioning & Replacing V-Belts

V-belts stretch and wear with use, so it is important that tension is routinely checked and adjusted as needed. Improperly tensioned V-belts will slip or poorly transmit power from the motor. We recommend checking the tension on a monthly basis to ensure optimal power transmission. Replace the V-belt if it becomes cracked, frayed, or glazed. Keep belts and pulleys clear of exposure to oil, grease, or cutting fluids that will cause them to slip.

Tool Needed	Qty
Hex Wrench 4mm.....	1

Tensioning V-Belts

1. DISCONNECT MACHINE FROM POWER!
2. Open end cover.
3. Loosen tensioner hex bolt (see **Figure 119**).

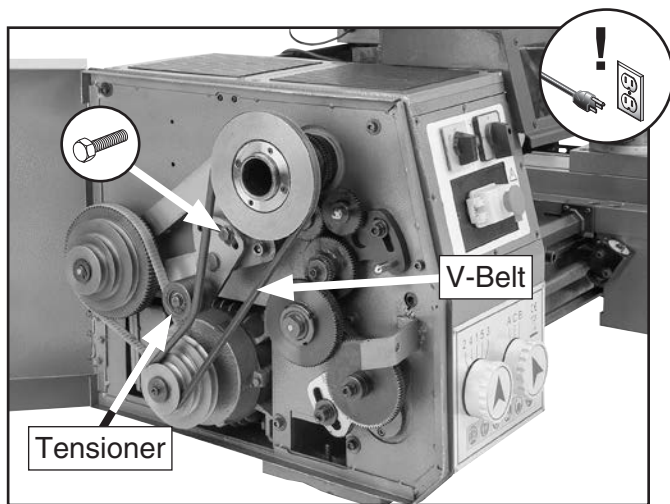

Figure 119. Tensioner bolt and V-belt.

4. Pivot tensioner (see **Figure 119**) against V-belt to increase belt tension, then re-tighten tensioner hex bolt.

The V-belt is correctly tensioned when there is approximately 1/8" deflection when pushed with moderate pressure between the pulleys, as shown in **Figure 120**.

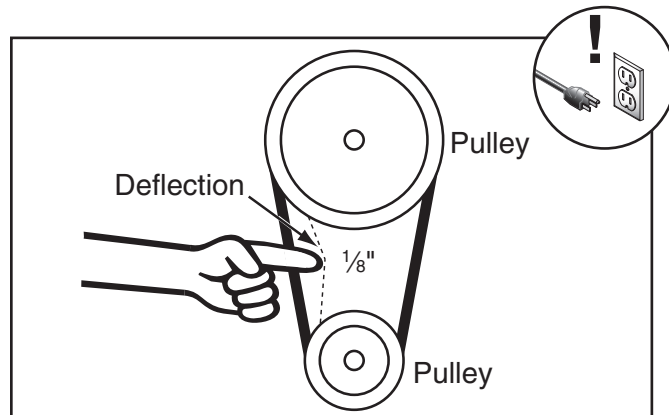

Figure 120. Correct V-belt deflection.

—If there is more than 1/8" deflection, adjust tension until it is correct.

5. Close end cover.

Replacing V-Belts

1. DISCONNECT MACHINE FROM POWER!
2. Open end cover.
3. Loosen tensioner bolt (see **Figure 119**) to relieve tension on V-belt.
4. Carefully roll V-belt off of pulleys.
5. Install new V-belt, then tension as described in **Tensioning V-Belts**.



Adjusting Backlash

Backlash is the amount of free play felt while changing rotation directions with the handwheel. This can be adjusted on the cross slide leadscrew. Before beginning any adjustment, make sure all associated components are cleaned and lubricated and locks are loose.

When adjusting backlash, tighten the components enough to remove backlash, but not so much that the components bind the leadscrew, making it hard to turn. Overtightening will cause excessive wear to the nut and leadscrew.

NOTICE

Reducing backlash to less than 0.002" is impractical and can lead to accelerated wear in leadscrew and other components. Avoid temptation to overtighten leadscrew nut or set screw while adjusting.

Cross Slide

Tool Needed: Qty
Hex Wrench 4mm 1

The cross slide backlash is adjusted by tightening and loosening the set screw shown in **Figure 121**.

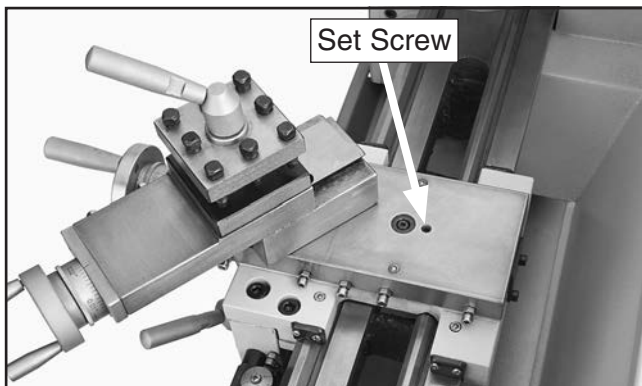

Figure 121. Example of cross slide backlash adjustment.

Move the cross slide handwheel back and forth while adjusting set screw until backlash is approximately 0.002"–0.003", as indicated on the graduated dial.

Adjusting Leadscrew End Play

A small amount of end play is normal, however after a long period of time, you may find that the leadscrew develops excessive end play. This can be removed with a simple adjustment of the nuts at the end of the leadscrew.

Tools Needed Qty
Hex Wrench 6mm..... 1
Open-End Wrench 19mm..... 1

To remove leadscrew end play:

1. DISCONNECT MACHINE FROM POWER!
2. Loosen jam nut shown in **Figure 122**.

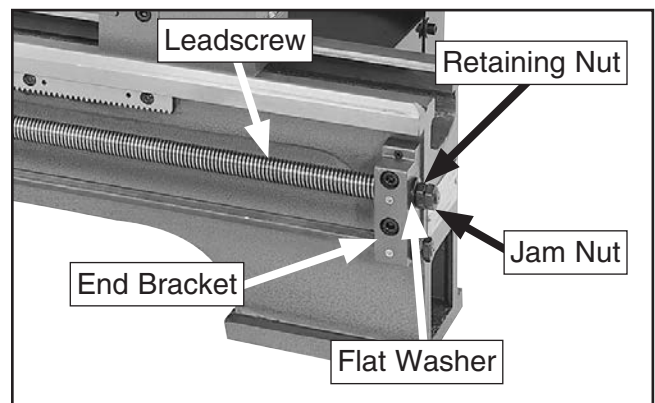

Figure 122. Leadscrew end play adjustments.

3. Using your fingers, tighten retaining nut until it firmly pushes flat washer against end bracket, then back retaining nut off $\frac{1}{8}$ turn.
4. Hold retaining nut in position and tighten jam nut against it until snug.



Adjusting Gibs

The goal of adjusting the gib screws is to remove sloppiness or "play" from the ways without over-adjusting them to the point where they become stiff and difficult to move.

In general, loose gibs cause poor finishes and tool chatter; however, over-tightened gibs cause premature wear and make it difficult to turn the handwheels.

The cross-slide and compound slide both use a straight gib, which is adjusted with cap screws and hex nuts along its length. The screws push the gib in to create more contact with the sliding surfaces. The Z-axis ways use a tapered gib, which is adjusted with screws on each end.

The gib adjustment process usually requires some trial-and-error. Repeat the process as necessary until you find the best balance between loose and stiff movement. Most machinists find that the ideal gib adjustment is one where a small amount of drag or resistance is present, yet the handwheels are still somewhat easy to move.

Clean and lubricate the ways before beginning any adjustments. Refer to **Lubrication** on **Page 62** for instructions and lubricant specifications.

Tools Needed	Qty
Open-End Wrench 10mm.....	1
Hex Wrench 3mm.....	1
Flat Head Screwdriver #2.....	1

Adjusting Cross Slide & Compound Slide Gibs

1. DISCONNECT MACHINE FROM POWER!
2. Loosen hex nuts on side of cross slide or compound slide (see **Figures 123**).

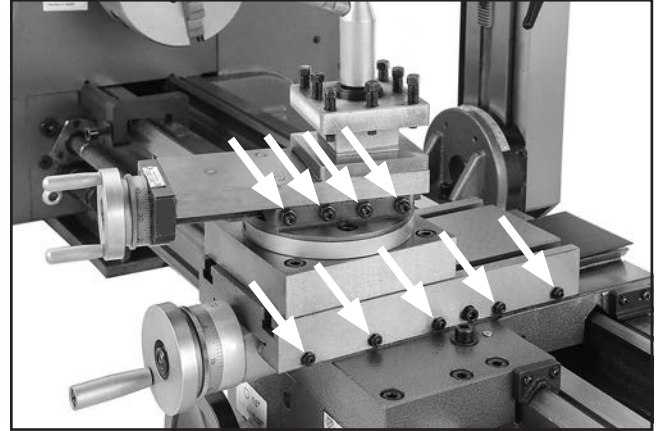

Figure 123. Gib adjustment hex nuts and cap screws.

3. Adjust all corresponding cap screws in small and equal increments while testing movement of slide by rotating handwheel.

Note: Turn cap screws clockwise to tighten the gib, or counterclockwise to loosen the gib.

4. When satisfied with gib adjustment, use hex wrench to prevent set screws from moving, then retighten hex nuts to secure settings.
5. Re-check movement of slide and, if necessary, repeat **Steps 2–4**.



Adjusting Half Nut

The rigidity of the half nut engagement is adjusted by tightening or loosening the half nut gib screws. Adjust the half nut if it feels too loose or too tight when being engaged. Movement that is too stiff will accelerate wear. Movement that is too sloppy will produce inaccurate turning or threading results.

Tools Needed	Qty
Open-End Wrench 7mm.....	1
Hex Wrench 3mm.....	1

To adjust half nut:

1. DISCONNECT MACHINE FROM POWER!
2. Disengage half nut.

3. Loosen gib nuts and adjust screws in small, even increments so one end of the gib does not become tighter than the other (see **Figure 124**).

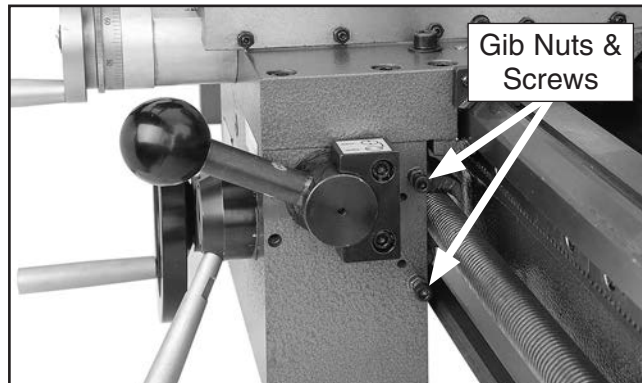

Figure 124. Half nut gib adjustment set screws.

4. Engage/disengage half nut several times and notice how it feels. The adjustment is correct when half nut firmly and easily engages leadscrew while opening and closing.
5. Repeat **Steps 3–4**, if necessary, until satisfied with feel of half nut engagement.
6. Re-tighten gib nuts to secure position of adjustment screws.



SECTION 9: WIRING

These pages are current at the time of printing. However, in the spirit of improvement, we may make changes to the electrical systems of future machines. Compare the manufacture date of your machine to the one stated in this manual, and study this section carefully.

If there are differences between your machine and what is shown in this section, call Technical Support at (570) 546-9663 for assistance BEFORE making any changes to the wiring on your machine. An updated wiring diagram may be available. **Note:** *Please gather the serial number and manufacture date of your machine before calling. This information can be found on the main machine label.*

WARNING

Wiring Safety Instructions

SHOCK HAZARD. Working on wiring that is connected to a power source is extremely dangerous. Touching electrified parts will result in personal injury including but not limited to severe burns, electrocution, or death. Disconnect the power from the machine before servicing electrical components!

MODIFICATIONS. Modifying the wiring beyond what is shown in the diagram may lead to unpredictable results, including serious injury or fire. This includes the installation of unapproved after-market parts.

WIRE CONNECTIONS. All connections must be tight to prevent wires from loosening during machine operation. Double-check all wires disconnected or connected during any wiring task to ensure tight connections.

CIRCUIT REQUIREMENTS. You MUST follow the requirements at the beginning of this manual when connecting your machine to a power source.

WIRE/COMPONENT DAMAGE. Damaged wires or components increase the risk of serious personal injury, fire, or machine damage. If you notice that any wires or components are damaged while performing a wiring task, replace those wires or components.

MOTOR WIRING. The motor wiring shown in these diagrams is current at the time of printing but may not match your machine. If you find this to be the case, use the wiring diagram inside the motor junction box.















CAPACITORS/INVERTERS. Some capacitors and power inverters store an electrical charge for up to 10 minutes after being disconnected from the power source. To reduce the risk of being shocked, wait at least this long before working on capacitors.

EXPERIENCING DIFFICULTIES. If you are experiencing difficulties understanding the information included in this section, contact our Technical Support at (570) 546-9663.

NOTICE

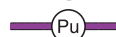
The photos and diagrams included in this section are best viewed in color. You can view these pages in color at www.grizzly.com.

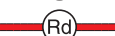
COLOR KEY

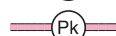
BLACK		BLUE		YELLOW		LIGHT BLUE	
WHITE		BROWN		YELLOW GREEN		BLUE WHITE	
GREEN		GRAY		PURPLE		TURQUOISE	
RED		ORANGE		PINK			



Wiring Overview

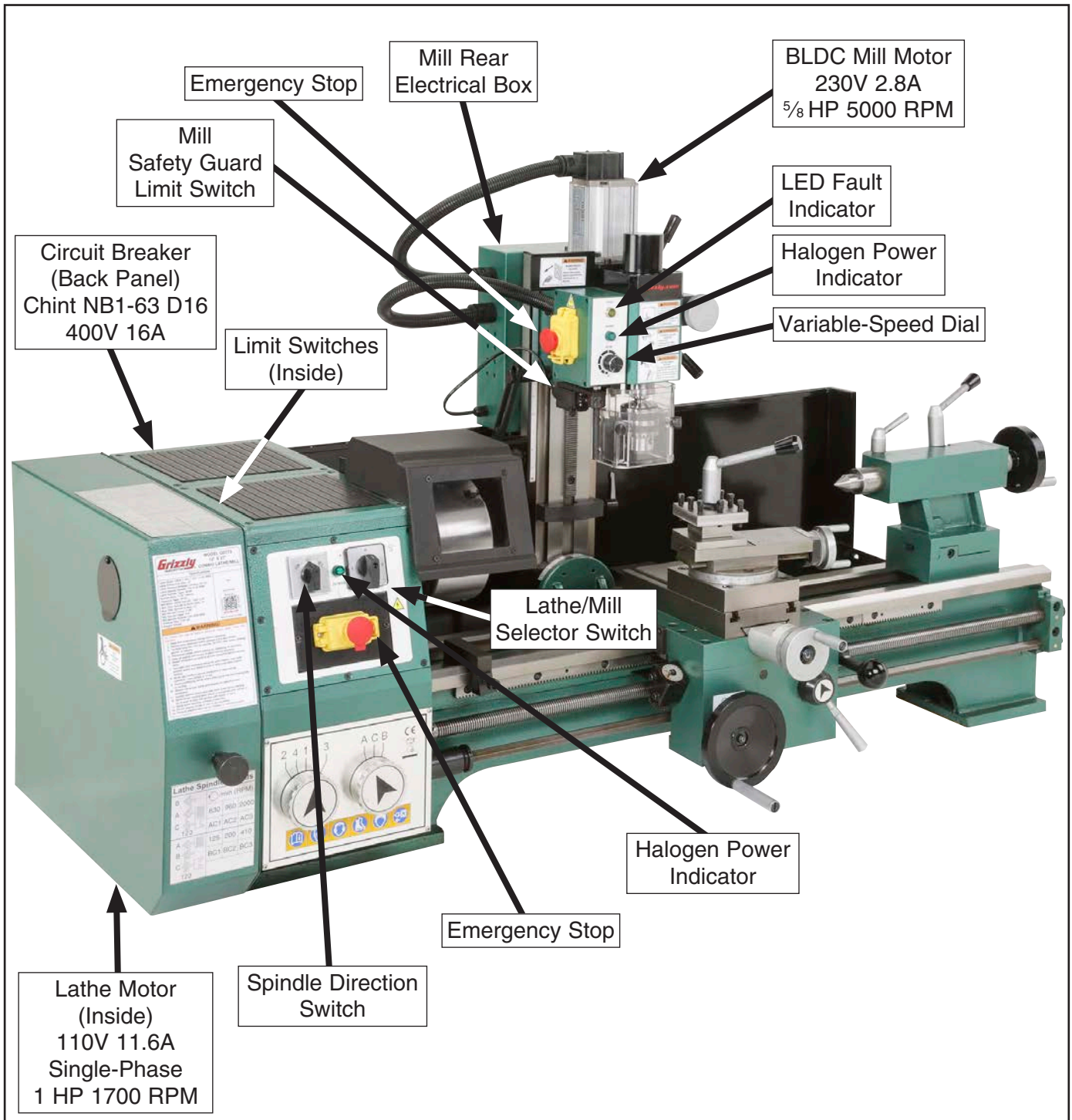

Wiring Diagram

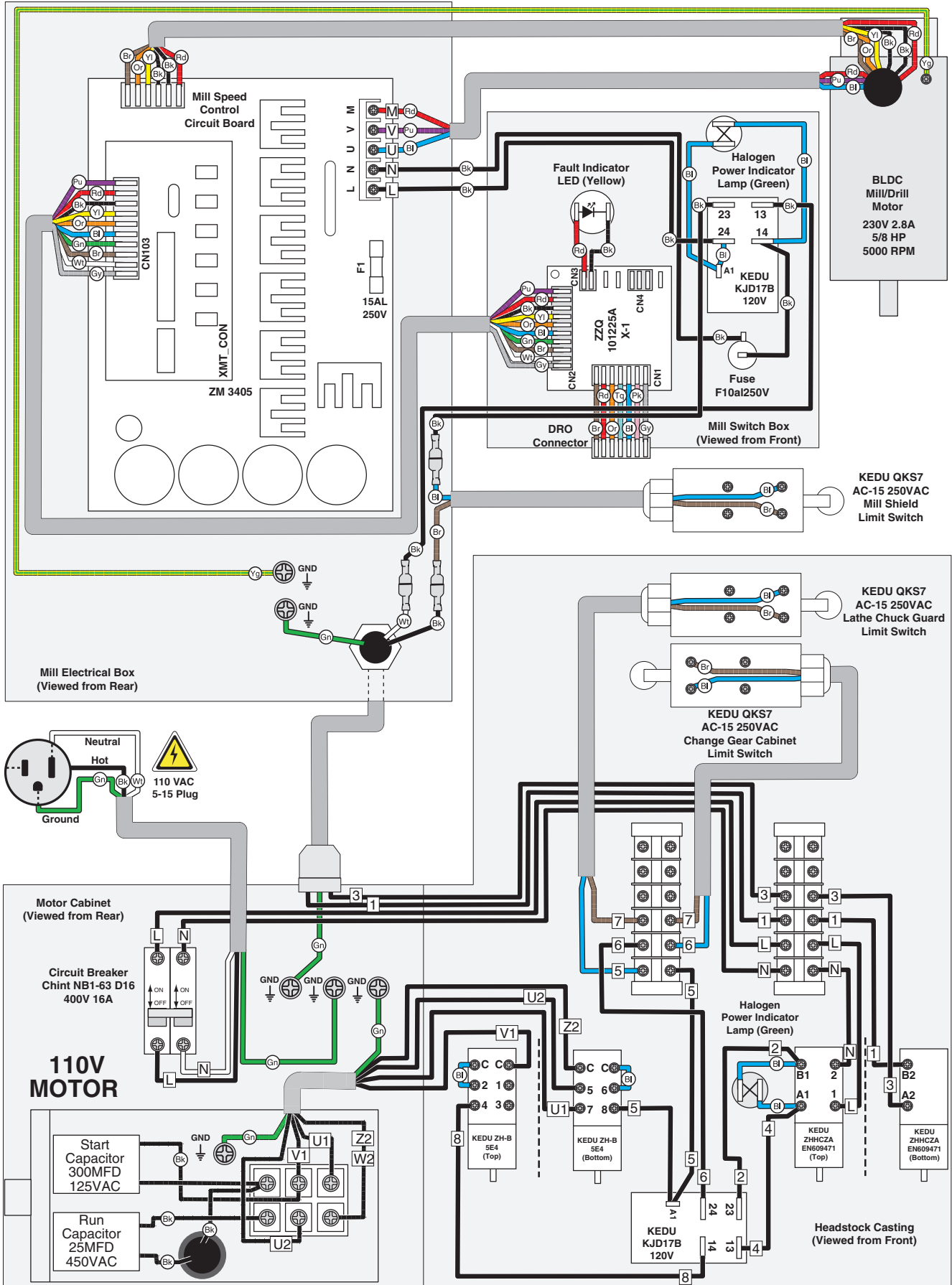

Wiring Photos

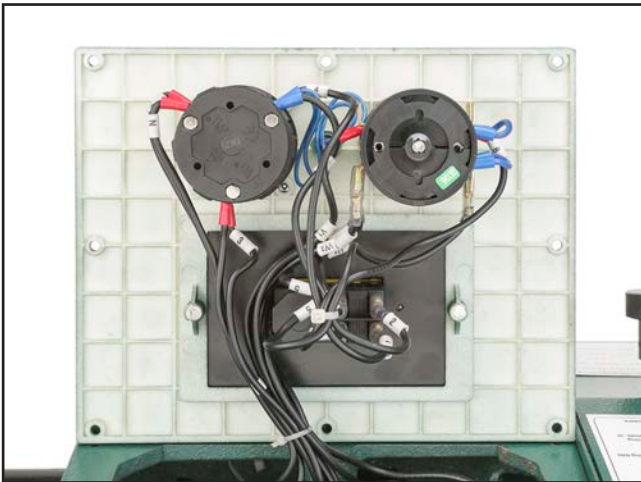

Figure 125. Control panel.



Figure 128. Headstock casting.

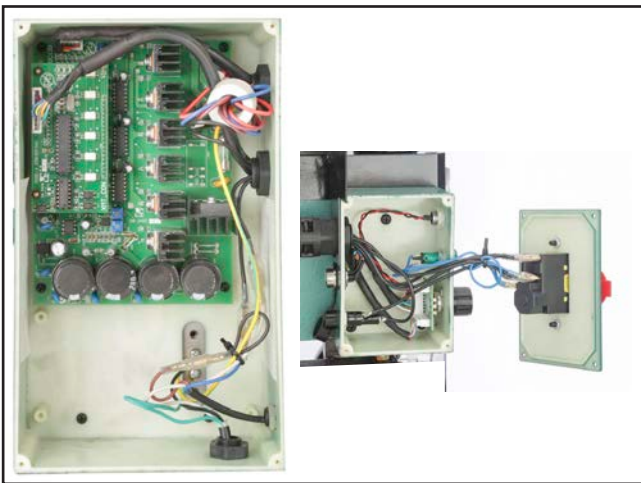

Figure 126. Mill rear electrical box and switch box.

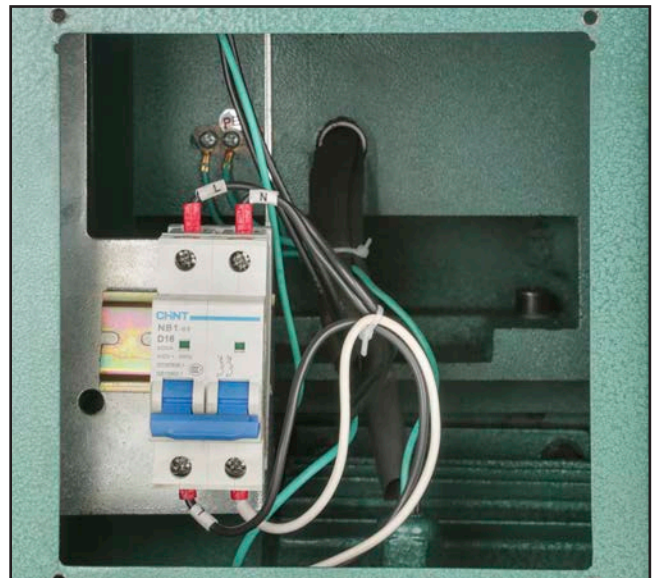

Figure 129. Back panel.



Figure 127. Mill/drill motor.

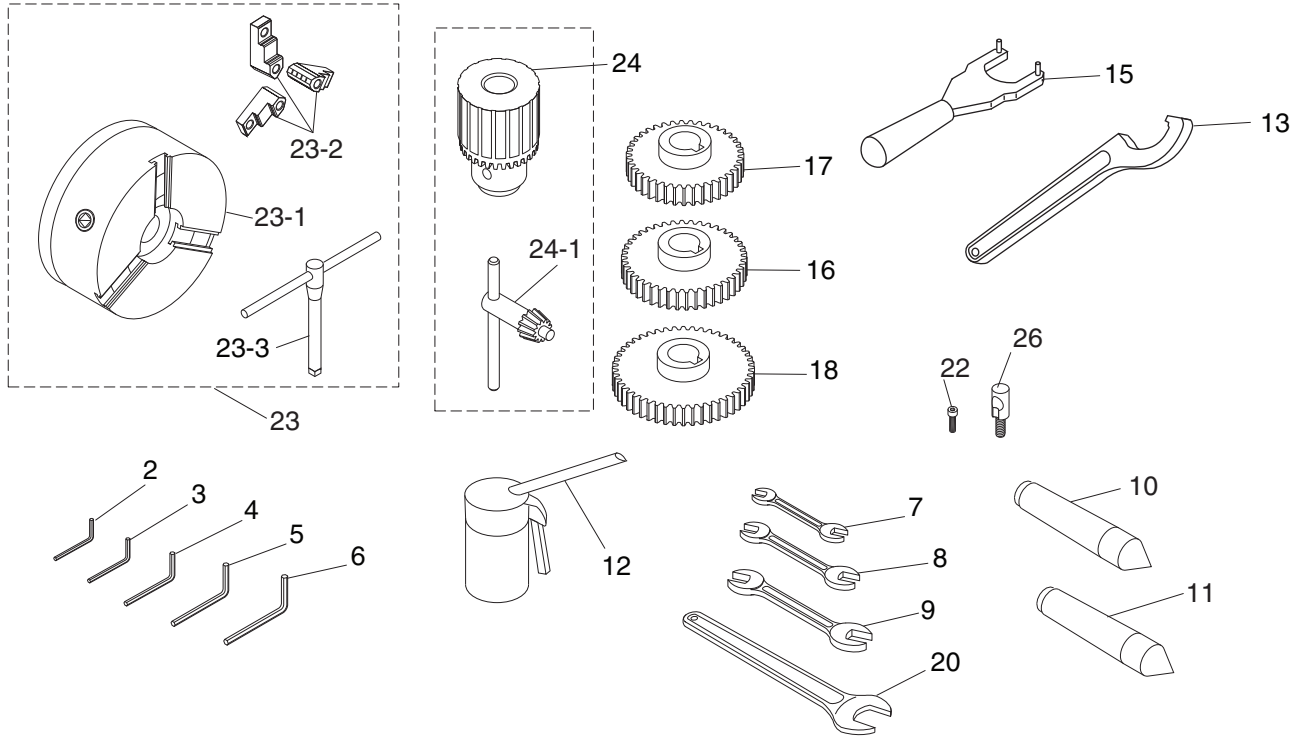

Figure 130. Start and run capacitors.



SECTION 10: PARTS

Accessories



REF	PART #	DESCRIPTION
2	P07730002	HEX WRENCH 3MM
3	P07730003	HEX WRENCH 4MM
4	P07730004	HEX WRENCH 5MM
5	P07730005	HEX WRENCH 6MM
6	P07730006	HEX WRENCH 8MM
7	P07730007	WRENCH 8 X 10MM OPEN-ENDS
8	P07730008	WRENCH 12 X 14MM OPEN-ENDS
9	P07730009	WRENCH 17 X 19MM OPEN-ENDS
10	P07730010	DEAD CENTER MT#3
11	P07730011	DEAD CENTER MT#5
12	P07730012	BOTTLE FOR OIL
13	P07730013	SPANNER WRENCH 45-52MM HOOK-TYPE
15	P07730015	SPANNER WRENCH 63MM PIN-TYPE

REF	PART #	DESCRIPTION
16	P07730016	CHANGE GEAR 50T
17	P07730017	CHANGE GEAR 35T
18	P07730018	CHANGE GEAR 60T
20	P07730020	WRENCH 36MM OPEN-END
22	P07730022	CAP SCREW M6-1 X 10
23	P07730023	3-JAW CHUCK 6"
23-1	P07730023-1	CHUCK 6" D1-5
23-2	P07730023-2	EXTERNAL JAW SET
23-3	P07730023-3	LATHE CHUCK KEY
24	P07730024	DRILL CHUCK B-16 1-13MM
24-1	P07730025	DRILL CHUCK KEY 5/16" AH 11T SD-5/8
26	P07730026	CAMLOCK STUD D1-5

Please Note: We do our best to stock replacement parts whenever possible, but we cannot guarantee that all parts shown here are available for purchase. Call (800) 523-4777 or visit our online parts store at www.grizzly.com to check for availability.



Lathe Bed

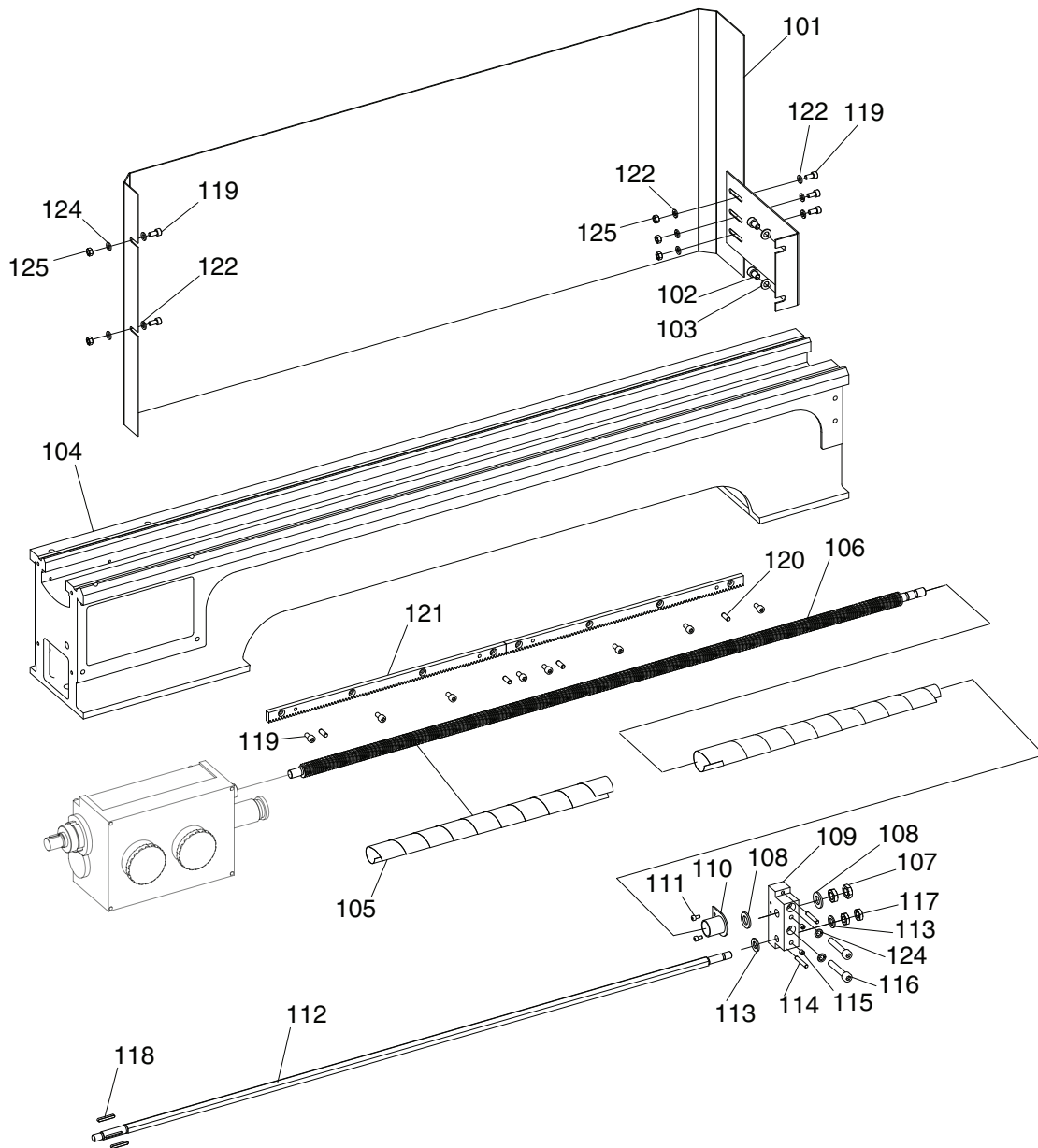

REF	PART #	DESCRIPTION
101	P07730101	SPLASH GUARD
102	P07730102	CAP SCREW M8-1.25 X 12
103	P07730103	FLAT WASHER 8MM
104	P07730104	LATHE BED
105	P07730105	LEADSCREW SHIELD
106	P07730106	LEADSCREW
107	P07730107	HEX NUT M12-1.5 THIN
108	P07730108	FLAT WASHER 12MM
109	P07730109	LEADSCREW BRACKET
110	P07730110	PROTECTIVE SUPPORT
111	P07730111	CAP SCREW M4-.7 X 8
112	P07730112	FEED ROD

REF	PART #	DESCRIPTION
113	P07730113	FLAT WASHER 10MM
114	P07730114	DOWEL PIN 8 X 30
115	P07730115	BALL OILER 6MM PRESS-IN
116	P07730116	CAP SCREW M8-1.25 X 45
117	P07730117	HEX NUT M10-1.25 THIN
118	P07730118	KEY 4 X 4 X 28
119	P07730119	CAP SCREW M6-1 X 12
120	P07730120	DOWEL PIN 8 X 16
121	P07730121	BED RACK
122	P07730122	FLAT WASHER 6MM
124	P07730124	LOCK WASHER 6MM
125	P07730125	HEX NUT M6-1



Headstock

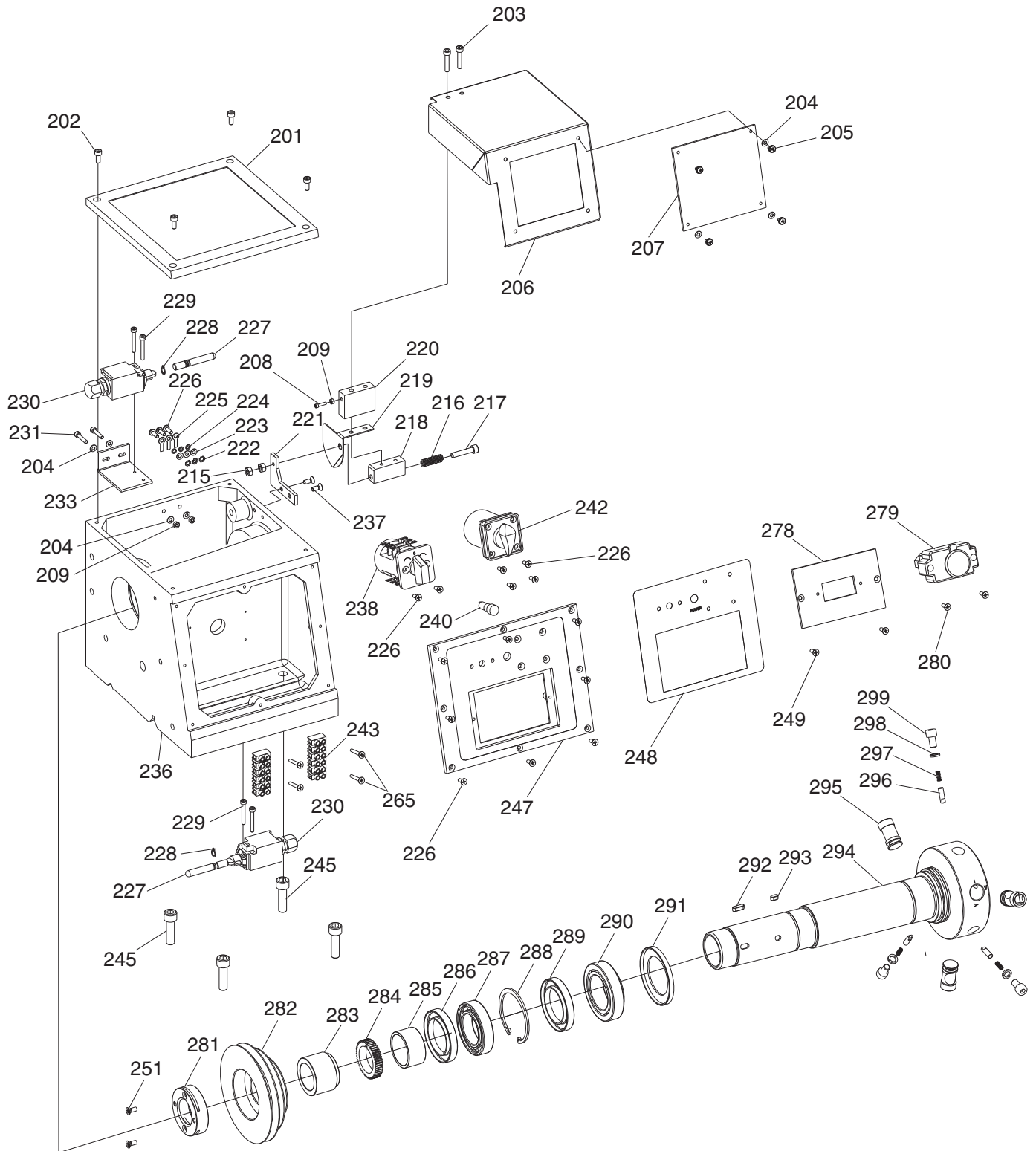

Headstock Parts List

REF	PART #	DESCRIPTION
201	P07730201	HEADSTOCK COVER
202	P07730202	CAP SCREW M5-.8 X 12
203	P07730203	FLAT HD SCR M5-.8 X 30
204	P07730204	FLAT WASHER 4MM
205	P07730205	FLAT HD SCR M4-.7 X 8
206	P07730206	LATHE CHUCK GUARD
207	P07730207	LATHE CHUCK GUARD WINDOW
208	P07730208	CAP SCREW M4-.7 X 16
209	P07730209	HEX NUT M4-.7
215	P07730215	HEX NUT M5-.8
216	P07730216	COMPRESSION SPRING
217	P07730217	CAP SCREW M5-.8 X 50
218	P07730218	LATHE CHUCK GUARD MOUNTING BRACKET
219	P07730219	LATHE CHUCK GUARD HARD STOP
220	P07730220	LATHE CHUCK GUARD SHIM
221	P07730221	LATHE CHUCK GUARD BRACE
222	P07730222	EXT TOOTH WASHER 4MM
223	P07730223	FLAT WASHER 4MM
224	P07730224	LOCK WASHER 4MM
225	P07730225	GROUND LUG
226	P07730226	PHLP HD SCR M4-.7 X 12
227	P07730227	PIN SHAFT
228	P07730228	EXT RETAINING RING 8MM
229	P07730229	CAP SCREW M4-.7 X 30
230	P07730230	LIMIT SWITCH KEDU QKS7 AC15 250V
231	P07730231	CAP SCREW M4-.7 X 20
233	P07730233	MICRO SWITCH MOUNTING PLATE
236	P07730236	HEADSTOCK CASTING
237	P07730237	FLAT HD CAP SCR M5-.8 X 12
238	P07730238	ROTARY SWITCH KEDU ZH-B FOR/OFF/REV
240	P07730240	POWER INDICATOR LIGHT ZD10

REF	PART #	DESCRIPTION
242	P07730242	ROTARY SWITCH KEDU ZH-HC-2 1/0/2
243	P07730243	TERMINAL BLOCK 12P
245	P07730245	CAP SCREW M10-1.5 X 35
247	P07730247	HEADSTOCK SWITCH PANEL
248	P07730248	SWITCH PANEL FACEPLATE
249	P07730249	TAP SCREW M4 X 16
251	P07730251	FLAT HD SCR M5-.8 X 20
265	P07730265	PHLP HD SCR M2.5-.45 X 14
278	P07730278	ON/OFF SWITCH MOUNTING PLATE
279	P07730279	ON/OFF SWITCH KEDU KJD17B 120V
280	P07730280	FLAT HD SCR M4-.7 X 12
281	P07730281	SPINDLE LOCK NUT
282	P07730282	SPINDLE PULLEY
283	P07730283	SPINDLE SPACER
284	P07730284	SPINDLE GEAR
285	P07730285	SPINDLE SPACER
286	P07730286	OIL SEAL
287	P07730287	BALL BEARING 6010ZZ
288	P07730288	INT RETAINING RING 80MM
289	P07730289	OIL SEAL
290	P07730290	TAPERED ROLLER BEARING 32011
291	P07730291	OIL SEAL
292	P07730292	KEY 6 X 6 X 12
293	P07730293	KEY 6 X 6 X 8
294	P07730294	SPINDLE
295	P07730295	SPINDLE CAM
296	P07730296	REGISTER PIN
297	P07730297	COMPRESSION SPRING
298	P07730298	LOCK WASHER 8MM
299	P07730299	CAP SCREW M8-1.25 X 14



Tailstock

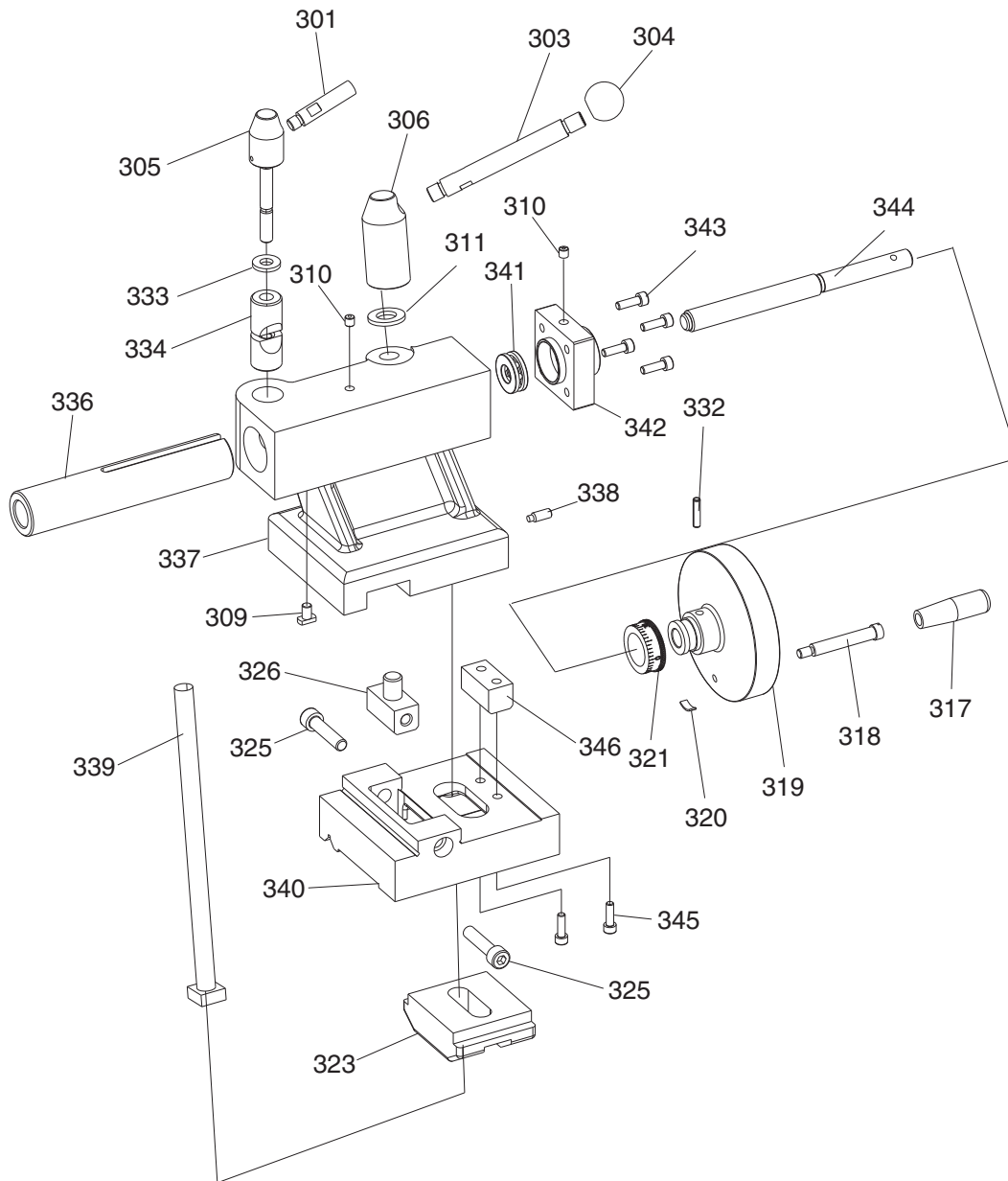

REF	PART #	DESCRIPTION
301	P07730301	QUILL LOCK HANDLE M8-1.25 X 10
303	P07730303	TAILSTOCK LOCK HANDLE M10-1.5 X 14
304	P07730304	TAILSTOCK LOCK HANDLE KNOB M10-1.5
305	P07730305	QUILL LOCK HANDLE BASE M8-1.25 X 30
306	P07730306	TAILSTOCK HANDLE BASE M12-1.75
309	P07730309	T-TAP FLAT KEY 12 X 12 X 7
310	P07730310	BALL OILER 6MM PRESS-IN
311	P07730311	FLAT WASHER 12MM
317	P07730317	QUILL HANDWHEEL HANDLE
318	P07730318	SHOULDER SCREW M6-1 X 10, 10 X 45
319	P07730319	HANDWHEEL 100MM DIA DISHED W/HANDLE
320	P07730320	HANDWHEEL CURVED PLATE SPRING
321	P07730321	GRADUATED COLLAR
323	P07730323	TAILSTOCK CLAMP PLATE
325	P07730325	CAP SCREW M8-1.25 X 35

REF	PART #	DESCRIPTION
326	P07730326	TAILSTOCK T-NUT 30 X 16 X 32 M8-1.25
332	P07730332	ROLL PIN 5 X 26
333	P07730333	FLAT WASHER 5MM
334	P07730334	TUBULAR CLAMP M8-1.25
336	P07730336	TAILSTOCK QUILL
337	P07730337	TAILSTOCK BODY
338	P07730338	SET SCREW M8-1.25 X 16 DOG-PT
339	P07730339	SQ HD BOLT M12-1.75 X 230
340	P07730340	TAILSTOCK BASE
341	P07730341	THRUST BEARING 51102
342	P07730342	TAILSTOCK END COVER
343	P07730343	CAP SCREW M8-1.25 X 16
344	P07730344	TAILSTOCK LEADSCREW
345	P07730345	CAP SCREW M6-1 X 25
346	P07730346	HARD STOP



Tool Post

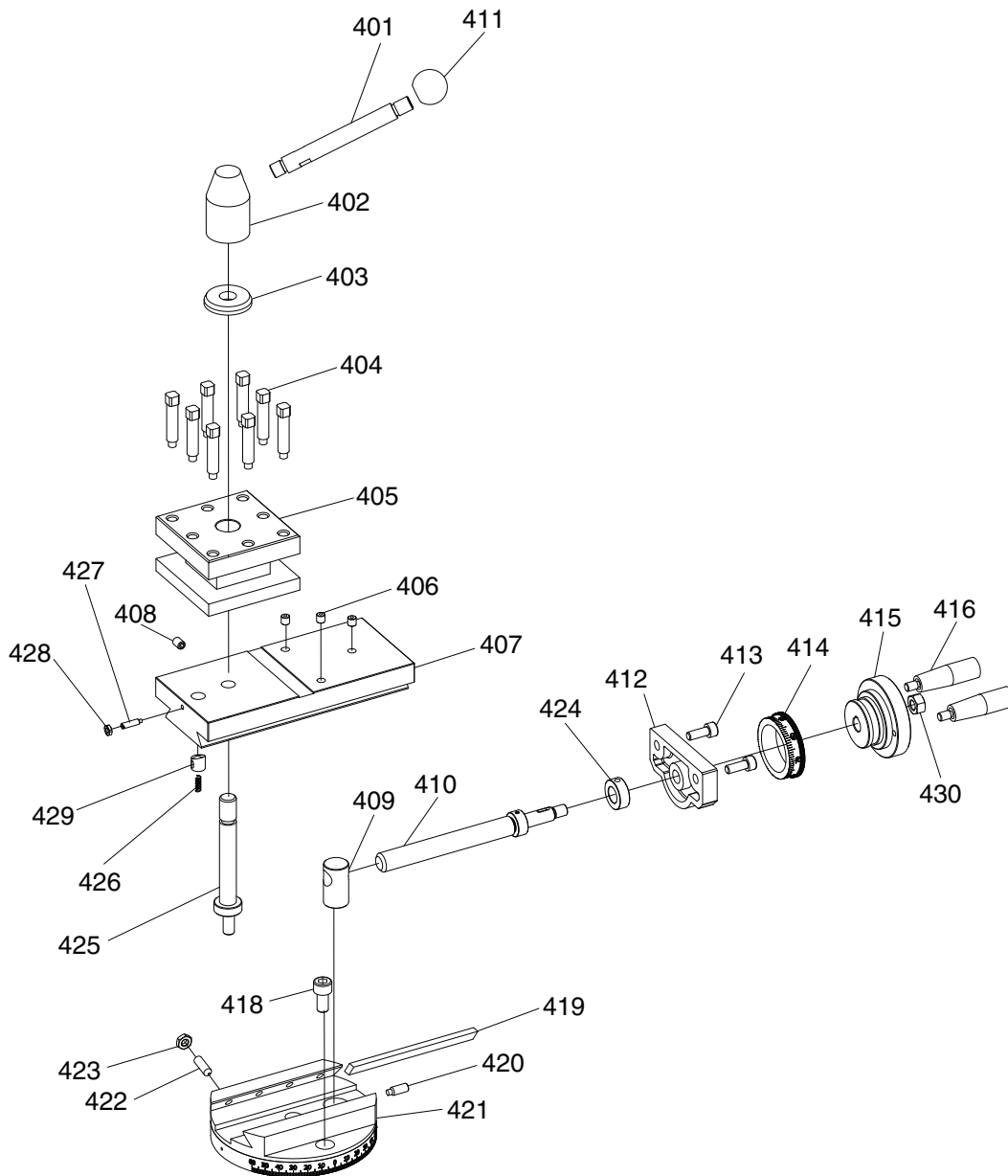

REF	PART #	DESCRIPTION
401	P07730401	TOOL POST LEVER M10-1.5
402	P07730402	TOOL POST LEVER BASE M12-1.75
403	P07730403	TOOL POST LEVER SPACER
404	P07730404	SQ HD BOLT M8-1.25 X 30
405	P07730405	TURRET TOOL HOLDER
406	P07730406	BALL OILER 6MM PRESS-IN
407	P07730407	COMPOUND REST
408	P07730408	SET SCREW M6-1 X 10 CONE-PT
409	P07730409	COMPOUND REST LEADSCREW NUT
410	P07730410	COMPOUND REST LEADSCREW
411	P07730411	TOOL POST LEVER KNOB M10-1.5
412	P07730412	LEADSCREW SUPPORT
413	P07730413	CAP SCREW M6-1 X 16
414	P07730414	GRADUATED COLLAR
415	P07730415	HANDWHEEL 68MM DIA FLAT W/HANDLE

REF	PART #	DESCRIPTION
416	P07730416	HANDWHEEL HANDLE M6-1 X 8
418	P07730418	CAP SCREW M8-1.25 X 16
419	P07730419	COMPOUND REST GIB
420	P07730420	SET SCREW M6-1 X 16 DOG-PT
421	P07730421	COMPOUND REST BASE
422	P07730422	SET SCREW M6-1 X 20 CONE-PT
423	P07730423	HEX NUT M6-1 THIN
424	P07730424	LEADSCREW COLLAR 6MM
425	P07730425	TOOL POST SHAFT M12-1.75
426	P07730426	COMPRESSION SPRING
427	P07730427	SET SCREW M4-.7 X 16 LONG DOG-PT
428	P07730428	HEX NUT M4-.7 THIN
429	P07730429	LOCKING PIN
430	P07730430	HEX NUT M8-1.25



Cross Slide

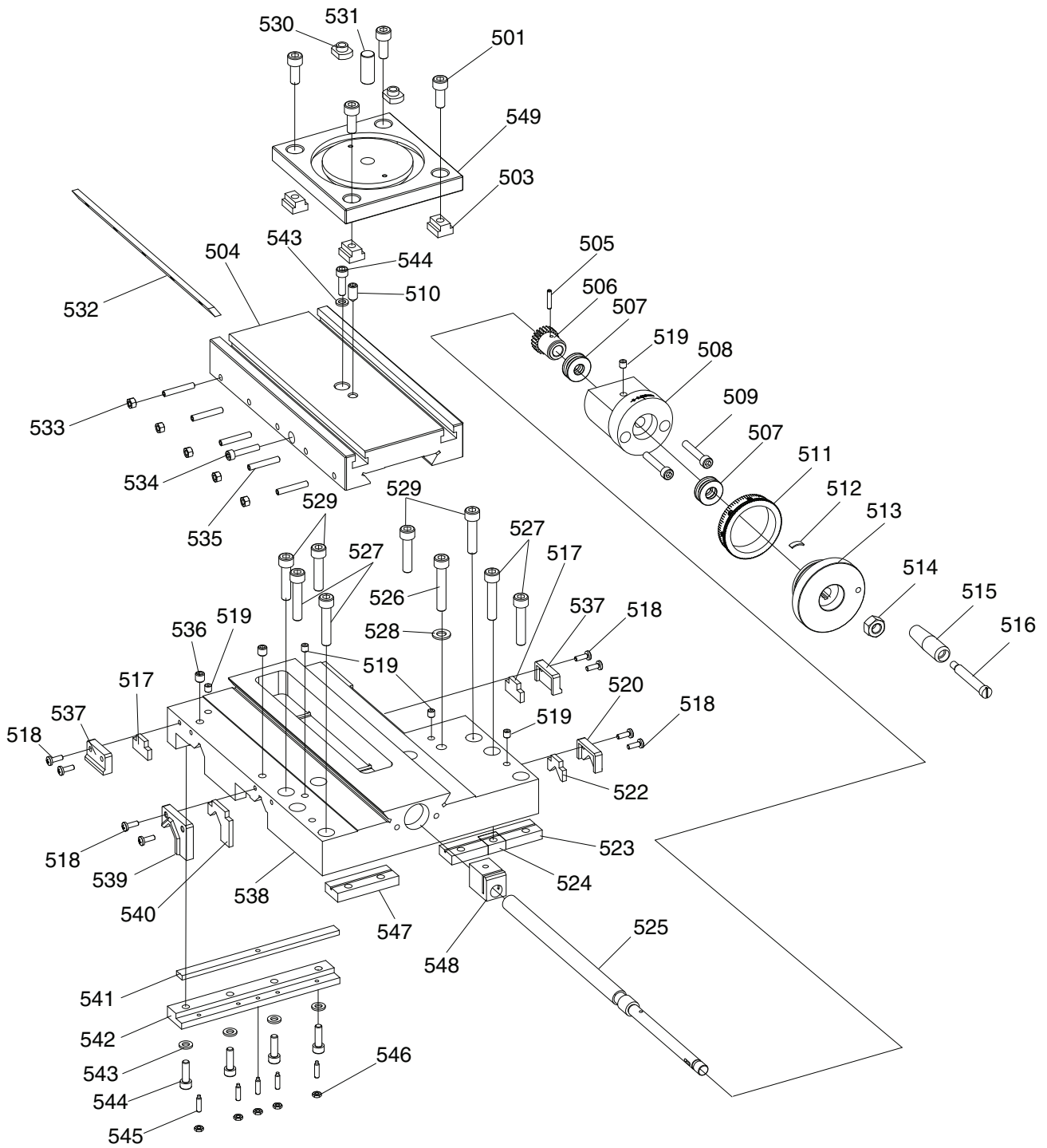

Cross Slide Parts List

REF PART #	DESCRIPTION
501	P07730501 CAP SCREW M8-1.25 X 20
503	P07730503 T-SLOT NUT 10MM, M8-1.25
504	P07730504 CROSS SLIDE CASTING
505	P07730505 ROLL PIN 3 X 18
506	P07730506 GEAR 22T
507	P07730507 THRUST BEARING 51100
508	P07730508 LEADSCREW HUB
509	P07730509 CAP SCREW M6-1 X 35
510	P07730510 SET SCREW M8-1.25 X 16 CONE-PT
511	P07730511 GRADUATED COLLAR
512	P07730512 HANDWHEEL CURVED PLATE SPRING
513	P07730513 HANDWHEEL 68MM DIA FLAT W/HANDLE
514	P07730514 HEX NUT M10-1.5
515	P07730515 HANDWHEEL HANDLE 50MM
516	P07730516 SHOULDER SCREW M6-1 X 8, 8 X 45
517	P07730517 STRAIGHT WAY WIPER
518	P07730518 PHLP HD SCR M4-.7 X 12
519	P07730519 BALL OILER 6MM PRESS-IN
520	P07730520 V-WAY WIPER COVER
522	P07730522 V-WAY WIPER
523	P07730523 CROSS SLIDE CLAMP, LARGE
524	P07730524 CROSS SLIDE CLAMP, SMALL
525	P07730525 CROSS SLIDE LEADSCREW
526	P07730526 CAP SCREW M8-1.25 X 45

REF PART #	DESCRIPTION
527	P07730527 CAP SCREW M8-1.25 X 40
528	P07730528 FLAT WASHER 8MM
529	P07730529 CAP SCREW M8-1.25 X 35
530	P07730530 T-SLOT NUT M8-1.25, ROUNDED
531	P07730531 COMPOUND REST MOUNTING POST
532	P07730532 CROSS SLIDE GIB
533	P07730533 HEX NUT M5-.8
534	P07730534 CAP SCREW M6-1 X 18
535	P07730535 SET SCREW M5-.8 X 30 CONE-PT
536	P07730536 SET SCREW M8-1.25 X 8
537	P07730537 STRAIGHT WAY WIPER COVER
538	P07730538 SADDLE CASTING
539	P07730539 V-WAY WIPER COVER, LONG
540	P07730540 V-WAY WIPER, LONG
541	P07730541 SADDLE GIB
542	P07730542 SADDLE CLAMP SLIDE
543	P07730543 FLAT WASHER 6MM
544	P07730544 CAP SCREW M6-1 X 20
545	P07730545 SET SCREW M4-.7 X 16 LONG DOG-PT
546	P07730546 HEX NUT M4-.7 THIN
547	P07730547 CROSS SLIDE CLAMP, MEDIUM
548	P07730548 SADDLE LEADSCREW NUT
549	P07730549 COMPOUND REST MOUNTING PLATE



Apron

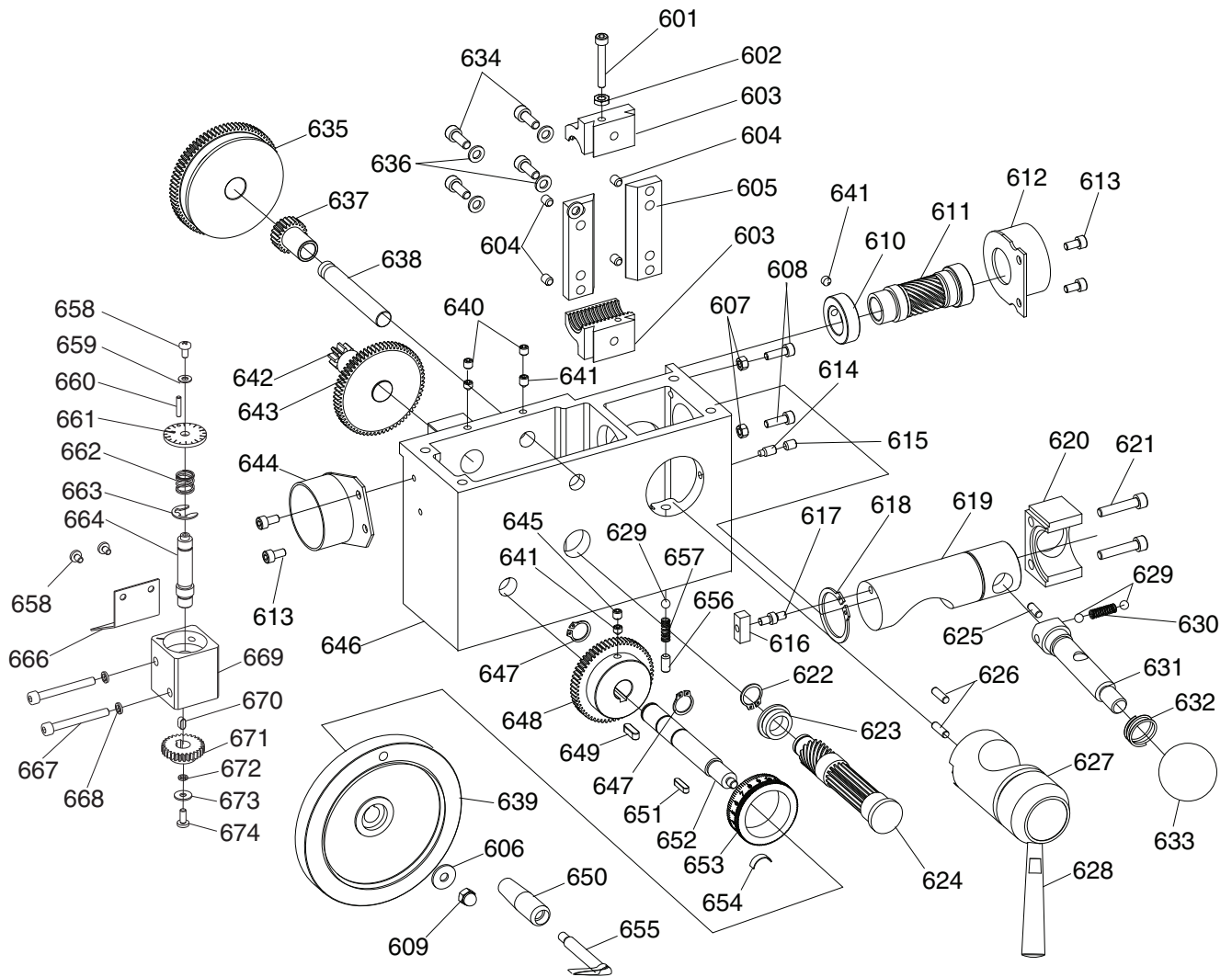

Apron Parts List

REF	PART #	DESCRIPTION
601	P07730601	CAP SCREW M5-.8 X 35
602	P07730602	HEX NUT M5-.8 THIN
603	P07730603	HALF NUT
604	P07730604	SET SCREW M8-1.25 X 10
605	P07730605	CARRIAGE CLAMP
606	P07730606	FENDER WASHER 6MM
607	P07730607	HEX NUT M5-.8
608	P07730608	CAP SCREW M5-.8 X 16
609	P07730609	ACORN NUT M6-1
610	P07730610	RETAINING COLLAR
611	P07730611	WORM GEAR
612	P07730612	CARRIAGE SUPPORT, RIGHT
613	P07730613	CAP SCREW M5-.8 X 10
614	P07730614	SET SCREW M6-1 X 12 DOG-PT
615	P07730615	SET SCREW M6-1 X 8
616	P07730616	ROCKER ARM
617	P07730617	ROCKER SHAFT
618	P07730618	EXT RETAINING RING 35MM
619	P07730619	FEED SELECTOR CAM SHAFT
620	P07730620	FEED SELECTOR SHAFT MOUNT
621	P07730621	CAP SCREW M6-1 X 30
622	P07730622	EXT RETAINING RING 15MM
623	P07730623	BUSHING
624	P07730624	GEARED SHAFT
625	P07730625	DOWEL PIN 5 X 12
626	P07730626	DOWEL PIN 5 X 16
627	P07730627	HALF NUT CAM
628	P07730628	HALF NUT LEVER M8-1.25 X 8
629	P07730629	STEEL BALL 6MM
630	P07730630	COMPRESSION SPRING
631	P07730631	FEED CONTROL SHAFT M12-1.75 X 18
632	P07730632	COMPRESSION SPRING
633	P07730633	FEED CONTROL SHAFT KNOB M12-1.75
634	P07730634	CAP SCREW M6-1 X 16
635	P07730635	GEAR 81T
636	P07730636	FLAT WASHER 6MM
637	P07730637	GEAR 22T

REF	PART #	DESCRIPTION
638	P07730638	SHAFT
639	P07730639	HANDWHEEL 122MM DIA DISHED
640	P07730640	SET SCREW M6-1 X 6
641	P07730641	SET SCREW M6-1 X 6 CONE-PT
642	P07730642	GEARED SHAFT
643	P07730643	GEAR 67T
644	P07730644	CARRIAGE SUPPORT, LEFT
645	P07730645	SET SCREW M6-1 X 8 CONE-PT
646	P07730646	CARRIAGE CASTING
647	P07730647	EXT RETAINING RING 14MM
648	P07730648	GEAR 60T
649	P07730649	KEY 5 X 5 X 16
650	P07730650	HANDWHEEL HANDLE 75MM
651	P07730651	KEY 4 X 4 X 16
652	P07730652	HANDWHEEL SHAFT
653	P07730653	GRADUATED COLLAR
654	P07730654	HANDWHEEL CURVED PLATE SPRING
655	P07730655	SHOULDER SCREW M8-1.25 X 10, 9 X 70
656	P07730656	SET SCREW M6-1 X 12
657	P07730657	COMPRESSION SPRING
658	P07730658	PHLP HD SCR M4-.7 X 8
659	P07730659	FLAT WASHER 4MM
660	P07730660	DIAL PIN
661	P07730661	THREAD DIAL
662	P07730662	COMPRESSION SPRING
663	P07730663	E-CLIP 9MM
664	P07730664	THREAD DIAL SHAFT
666	P07730666	THREAD DIAL GUARD
667	P07730667	CAP SCREW M5-.8 X 45
668	P07730668	FLAT WASHER 5MM
669	P07730669	THREAD DIAL CASTING
670	P07730670	KEY 4 X 4 X 8
671	P07730671	GEAR 28T
672	P07730672	LOCK WASHER 4MM
673	P07730673	FENDER WASHER 4MM
674	P07730674	PHLP HD SCR M4-.7 X 10



Gearbox

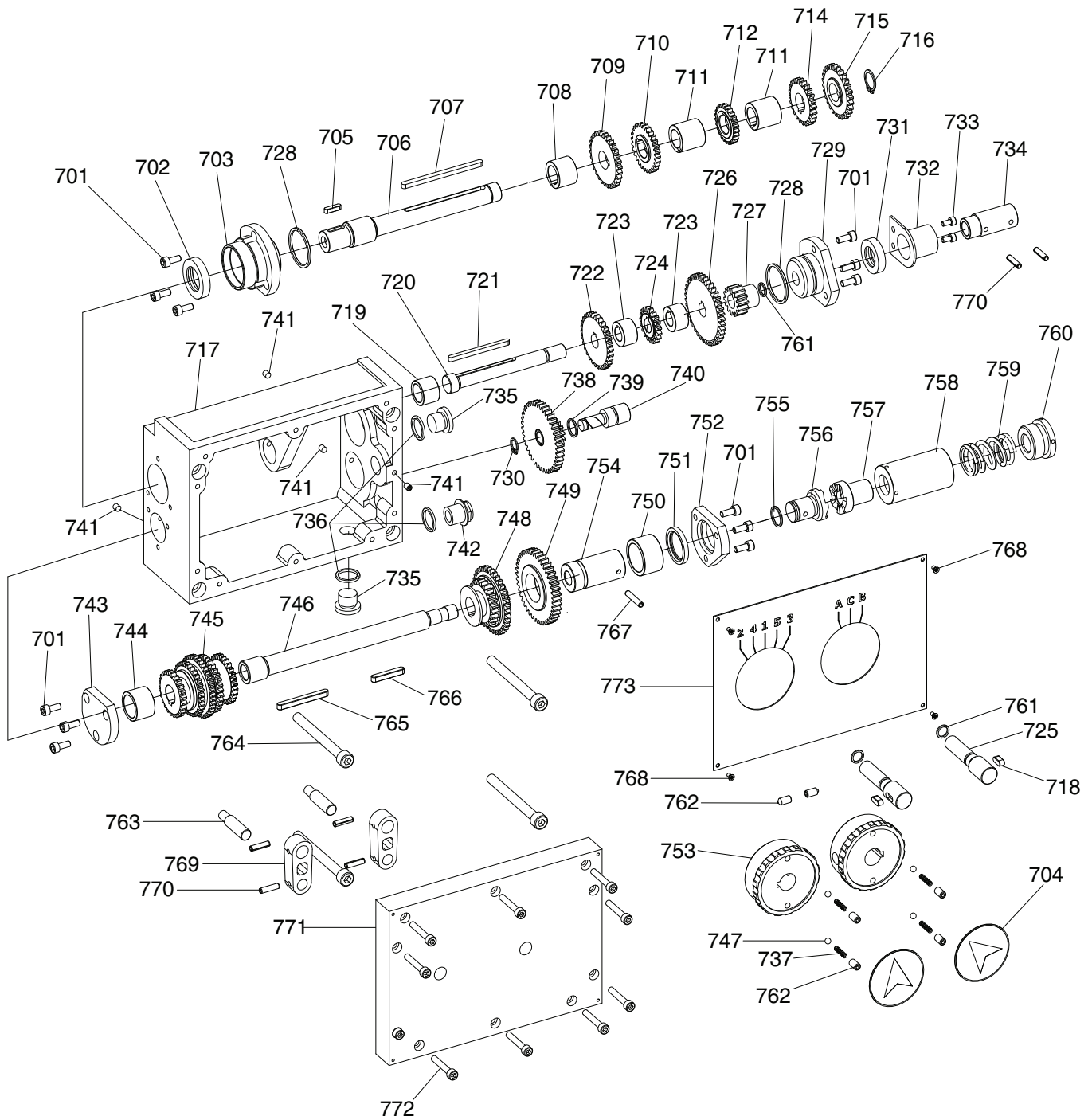

Gearbox Parts List

REF	PART #	DESCRIPTION
701	P07730701	CAP SCREW M5-.8 X 12
702	P07730702	OIL SEAL 22 X 35 X 7
703	P07730703	GASKET HOUSING
704	P07730704	INDICATOR PLATE
705	P07730705	KEY 4 X 4 X 16
706	P07730706	SHAFT
707	P07730707	KEY 5 X 5 X 80
708	P07730708	SPACER
709	P07730709	GEAR 30T
710	P07730710	GEAR 28T
711	P07730711	SPACER
712	P07730712	GEAR 25T
714	P07730714	GEAR 24T
715	P07730715	GEAR 28T
716	P07730716	EXT RETAINING RING 16MM
717	P07730717	GEARBOX CASTING
718	P07730718	KEY 5 X 5 X 12
719	P07730719	SPACER
720	P07730720	SHAFT
721	P07730721	KEY 5 X 5 X 60
722	P07730722	GEAR 30T
723	P07730723	SPACER
724	P07730724	GEAR 19T
725	P07730725	SELECTOR KNOB SHAFT
726	P07730726	GEAR 40T
727	P07730727	GEAR 14T
728	P07730728	O-RING 30 X 2.65
729	P07730729	SHAFT HUB
730	P07730730	EXT RETAINING RING 10MM
731	P07730731	OIL SEAL 18 X 30 X 7
732	P07730732	LEADSCREW SUPPORT
733	P07730733	CAP SCREW M4-.7 X 8
734	P07730734	CONNECTING COLLAR
735	P07730735	OIL PLUG M16-2 X 1.5
736	P07730736	O-RING 16 X 2.65
737	P07730737	COMPRESSION SPRING 0.7 X 4 X 25

REF	PART #	DESCRIPTION
738	P07730738	COMBO GEAR 13T/40T
739	P07730739	O-RING 12.5 X 1.8
740	P07730740	SHAFT
741	P07730741	SET SCREW M5-.8 X 8 CONE-PT
742	P07730742	SIGHT GLASS M16-2 X 1.5
743	P07730743	SHAFT END CAP
744	P07730744	SPACER, SMALL
745	P07730745	COMBO GEAR 24T/16T/38T/35T/24T
746	P07730746	SHAFT
747	P07730747	STEEL BALL 5MM
748	P07730748	COMBO GEAR 24T/16T/38T
749	P07730749	GEAR 42T
750	P07730750	SPACER, LARGE
751	P07730751	OIL SEAL 25 X 32 X 4
752	P07730752	GASKET HOUSING
753	P07730753	SELECTOR KNOB
754	P07730754	CLUTCH COUPLER
755	P07730755	O-RING 15 X 1.8
756	P07730756	CLUTCH, DRIVE SIDE
757	P07730757	CLUTCH, FOLLOW SIDE
758	P07730758	CLUTCH HOUSING
759	P07730759	COMPRESSION SPRING
760	P07730760	FEED ROD COUPLING
761	P07730761	O-RING 8.75 X 1
762	P07730762	SET SCREW M6-1 X 12 CONE-PT
763	P07730763	RETAINING PIN
764	P07730764	CAP SCREW M8-1.25 X 80
765	P07730765	KEY 5 X 5 X 50
766	P07730766	KEY 5 X 5 X 32
767	P07730767	ROLL PIN 4 X 24
768	P07730768	FLT HD SCR M3-.5 X 6
769	P07730769	DRIVING LEVER
770	P07730770	ROLL PIN 4 X 18
771	P07730771	GEARBOX COVER
772	P07730772	CAP SCREW M5-.8 X 30
773	P07730773	GEARBOX FACEPLATE



Change Gears

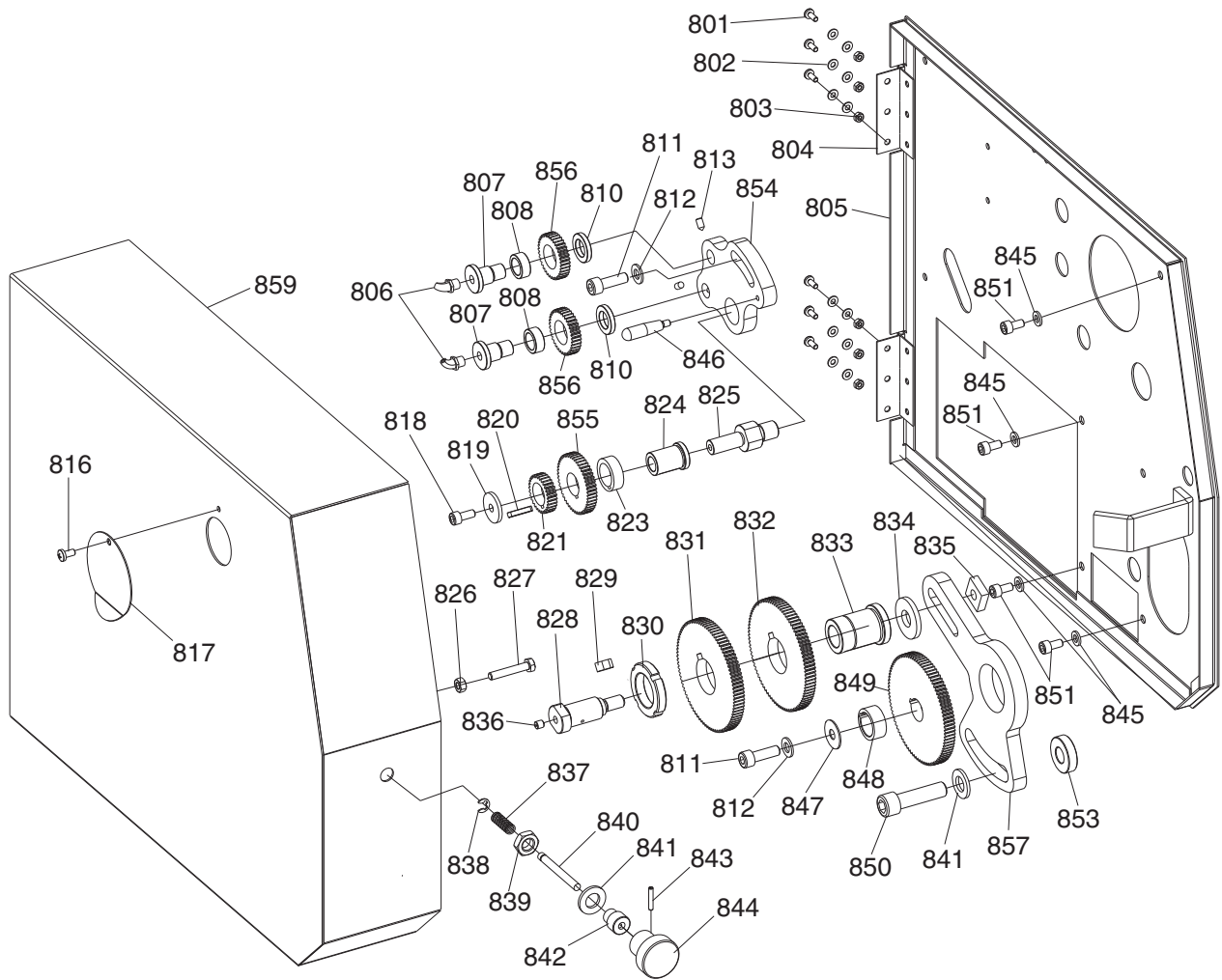

Change Gears Parts List

REF PART #	DESCRIPTION	
801	P07730801	PHLP HD SCR M4-.7 X 10
802	P07730802	FLAT WASHER 4MM
803	P07730803	HEX NUT M4-.7
804	P07730804	CHANGE GEAR ENCLOSURE HINGE
805	P07730805	CHANGE GEAR ENCLOSURE MOUNT
806	P07730806	GREASE FITTING 1/8PT 65-DEG
807	P07730807	SHAFT
808	P07730808	BUSHING
810	P07730810	SPACER
811	P07730811	CAP SCREW M8-1.25 X 25
812	P07730812	FLAT WASHER 8MM
813	P07730813	SET SCREW M5-.8 X 10 CONE-PT
816	P07730816	PHLP HD SCR M5-.8 X 10
817	P07730817	ACCESS PORT COVER
818	P07730818	CAP SCREW M6-1 X 14
819	P07730819	FENDER WASHER 6MM
820	P07730820	KEY 4 X 4 X 22
821	P07730821	GEAR 30T
823	P07730823	SPACER
824	P07730824	UPPER GEAR SUPPORT SHAFT
825	P07730825	UPPER GEAR AXLE
826	P07730826	HEX NUT M6-1
827	P07730827	HEX BOLT M6-1 X 35
828	P07730828	END GEAR AXLE M10-1.5 X 19
829	P07730829	KEY 8 X 7 X 14
830	P07730830	SPANNER NUT M30-1.5
831	P07730831	GEAR 86T

REF PART #	DESCRIPTION	
832	P07730832	GEAR 91T
833	P07730833	END GEAR SUPPORT SHAFT M30-1.5
834	P07730834	FENDER WASHER 10MM
835	P07730835	SQUARE NUT M10-1.5
836	P07730836	BALL OILER 6MM PRESS-IN
837	P07730837	COMPRESSION SPRING
838	P07730838	E-CLIP 12MM
839	P07730839	HEX NUT M12-1.75 THIN
840	P07730840	LOCKING PIN
841	P07730841	FLAT WASHER 12MM
842	P07730842	BUSHING
843	P07730843	ROLL PIN 3 X 30
844	P07730844	CHANGE GEAR CABINET KNOB
845	P07730845	FLAT WASHER 6MM
846	P07730846	SUPPORT ARM HANDLE M5-.8 X 8
847	P07730847	FENDER WASHER 8MM
848	P07730848	SPACER
849	P07730849	GEAR 90T
850	P07730850	CAP SCREW M12-1.75 X 45
851	P07730851	CAP SCREW M6-1 X 12
853	P07730853	SPACER
854	P07730854	UPPER SUPPORT ARM
855	P07730855	GEAR 65T
856	P07730856	GEAR 48T
857	P07730857	END GEAR SUPPORT ARM
859	P07730859	CHANGE GEAR CABINET DOOR



Motor & Drive

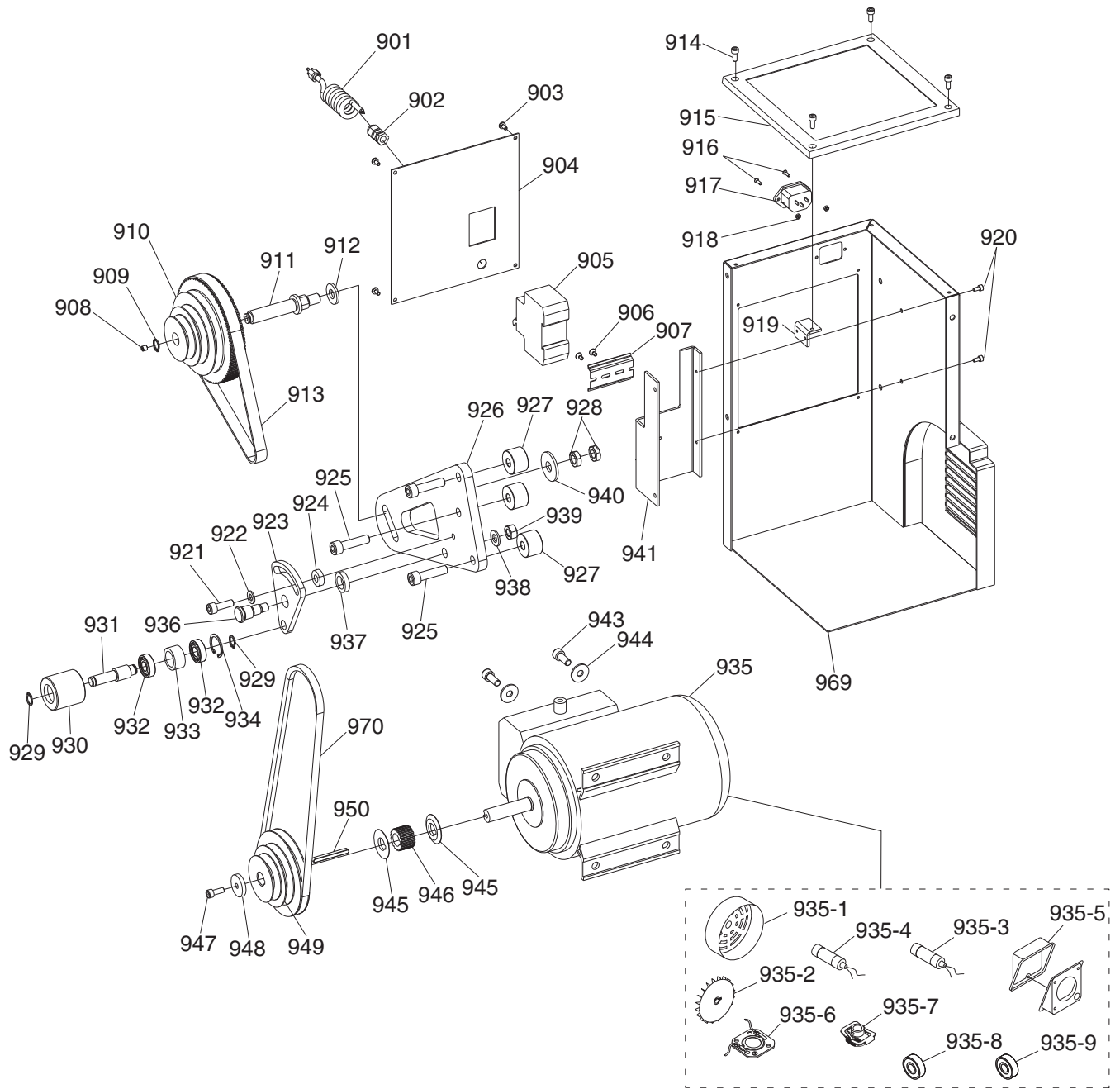

Motor & Drive Parts List

REF	PART #	DESCRIPTION
901	P07730901	POWER CORD 16G 3W 72" 5-15P
902	P07730902	STRAIN RELIEF M12-1.75 TYPE-3
903	P07730903	PHLP HD SCR M4-.7 X 8
904	P07730904	MOTOR ENCLOSURE COVER, BACK
905	P07730905	CIRCUIT BREAKER CHINT NB1-63 D16 400V
906	P07730906	FLAT HD SCR M4-.7 X 8
907	P07730907	DIN RAIL
908	P07730908	BALL OILER 6MM PRESS-IN
909	P07730909	EXT RETAINING RING 13MM
910	P07730910	TIMING BELT PULLEY
911	P07730911	TIMING BELT PULLEY SHAFT M12-1.5 X 30
912	P07730912	FENDER WASHER 12MM
913	P07730913	TIMING BELT 1.5 X 15 X 124
914	P07730914	CAP SCREW M5-.8 X 12
915	P07730915	MOTOR ENCLOSURE COVER, TOP
916	P07730916	FLAT HD SCR M3-.5 X 10
917	P07730917	SOCKET IEC 320 C14 110V
918	P07730918	HEX NUT M3-.5
919	P07730919	MOUNTING BRACKET
920	P07730920	CAP SCREW M4-.7 X 8
921	P07730921	CAP SCREW M8-1.25 X 25
922	P07730922	FLAT WASHER 8MM
923	P07730923	TENSIONER SUPPORT ARM
924	P07730924	SPACER
925	P07730925	CAP SCREW M10-1.5 X 40
926	P07730926	TIMING BELT SUPPORT ARM
927	P07730927	SPACER
928	P07730928	HEX NUT M12-1.75 THIN
929	P07730929	EXT RETAINING RING 12MM
930	P07730930	TENSIONER PULLEY

REF	PART #	DESCRIPTION
931	P07730931	TENSIONER PULLEY MANDREL
932	P07730932	BALL BEARING 6001-2RS
933	P07730933	SPACER
934	P07730934	INT RETAINING RING 28MM
935	P07730935	MOTOR 1HP 110V 1-PH
935-1	P07730935-1	MOTOR FAN COVER
935-2	P07730935-2	MOTOR FAN
935-3	P07730935-3	S CAPACITOR 150M 250V 1-5/8 X 3-1/8
935-4	P07730935-4	R CAPACITOR 20M 450V 1-1/2 X 2-3/4
935-5	P07730935-5	MOTOR JUNCTION BOX
935-6	P07730935-6	CONTACT PLATE
935-7	P07730935-7	CENTRIFUGAL SWITCH
935-8	P07730935-8	BALL BEARING 6204-2RS
935-9	P07730935-9	BALL BEARING 6204-2RS
936	P07730936	TENSIONER SUPPORT ARM SHAFT
937	P07730937	SPACER
938	P07730938	FLAT WASHER 10MM
939	P07730939	HEX NUT M10-1.5
940	P07730940	FENDER WASHER 12MM
941	P07730941	CIRCUIT BREAKER MOUNTING PLATE
943	P07730943	CAP SCREW M8-1.25 X 20
944	P07730944	FENDER WASHER 8MM
945	P07730945	SPACER
946	P07730946	MOTOR TIMING BELT PULLEY
947	P07730947	CAP SCREW M6-1 X 16
948	P07730948	FENDER WASHER 6MM
949	P07730949	MOTOR V-BELT PULLEY
950	P07730950	KEY 5 X 5 X 50
969	P07730969	MOTOR ENCLOSURE
970	P07730970	V-BELT 10X838



Mill

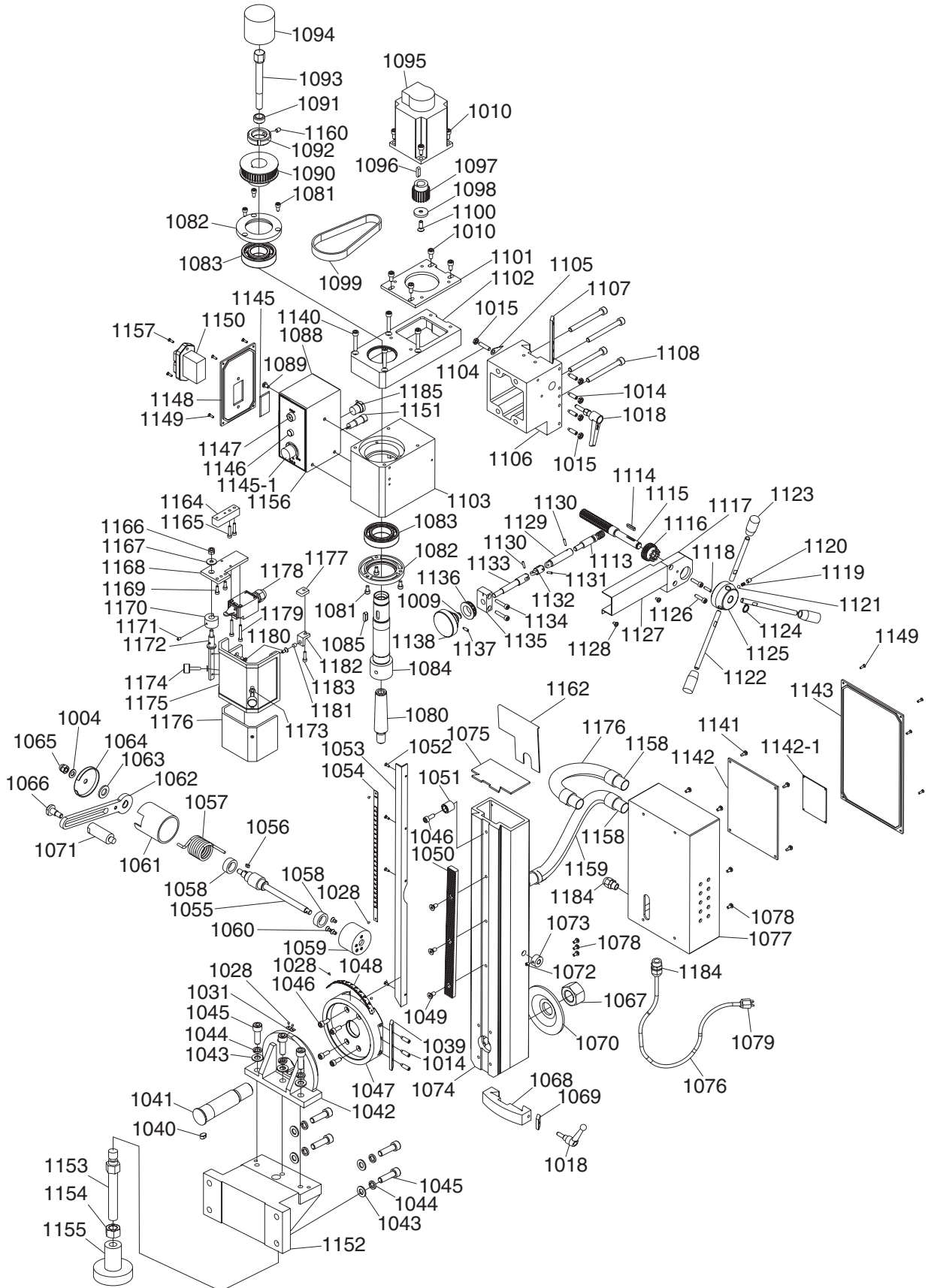

Mill Parts List

REF	PART #	DESCRIPTION
1004	P07731004	FLAT WASHER 8MM
1009	P07731009	HANDWHEEL CURVED PLATE SPRING
1010	P07731010	CAP SCREW M6-1 X 12
1014	P07731014	SET SCREW M6-1 X 20 DOG-PT
1015	P07731015	HEX NUT M6-1 THIN
1018	P07731018	LOCKING HANDLE
1028	P07731028	RIVET 2 X 3 FLUTED
1031	P07731031	POSITION MARKER
1039	P07731039	MILL TILT CLAMP
1040	P07731040	KEY 8 X 8 X 12
1041	P07731041	TILT SHAFT M24-3.0
1042	P07731042	MILL MOUNTING BRACKET
1043	P07731043	FLAT WASHER 10MM
1044	P07731044	LOCK WASHER 10MM
1045	P07731045	CAP SCREW M10-1.5 X 30
1046	P07731046	CAP SCREW M6-1 X 16
1047	P07731047	TILT HUB
1048	P07731048	GRADUATED PLATE
1049	P07731049	FLAT HD SCR M6-1 X 12
1050	P07731050	COLUMN RACK
1051	P07731051	HARD STOP
1052	P07731052	FLAT HD SCR M3-.5 X 8
1053	P07731053	COLUMN RACK BRACKET
1054	P07731054	GRADUATED DEPTH GAUGE
1055	P07731055	SHAFT
1056	P07731056	KEY 4 X 4 X 8
1057	P07731057	TORSION SPRING
1058	P07731058	SPACER
1059	P07731059	SPRING HOUSING
1060	P07731060	FLAT HD SCR M5-.8 X 8
1061	P07731061	SPRING SHROUD
1062	P07731062	SUPPORT BRACE
1063	P07731063	FLAT WASHER 12MM
1064	P07731064	END CAP
1065	P07731065	ACORN NUT M8-1.25
1066	P07731066	SHOULDER SCREW M8-1.25 X 12, 10 X 12
1067	P07731067	HEX NUT M24-3
1068	P07731068	DEPTH STOP
1069	P07731069	DEPTH STOP GIB
1070	P07731070	COLUMN TILT WASHER 24MM
1071	P07731071	STANDOFF M10-1.5 X 8
1072	P07731072	SET SCREW M5-.8 X 6 CONE-PT
1073	P07731073	RETAINING COLLAR
1074	P07731074	MILL COLUMN
1075	P07731075	COLUMN CAP
1076	P07731076	POWER CORD 18G 3W 72"
1077	P07731077	MILL ELECTRICAL BOX
1078	P07731078	PHLP HD SCR M4-.7 X 8
1079	P07731079	PLUG IEC 320 C14
1080	P07731080	ARBOR R-8 X B-16
1081	P07731081	CAP SCREW M5-.8 X 10
1082	P07731082	BEARING RETAINER
1083	P07731083	BALL BEARING 6206ZZ

REF	PART #	DESCRIPTION
1084	P07731084	SPINDLE R-8
1085	P07731085	KEY 6 X 6 X 18
1088	P07731088	MILL SWITCH BOX
1089	P07731089	PHLP HD SCR M5-.8 X 8
1090	P07731090	SPINDLE PULLEY
1091	P07731091	RETAINING COLLAR
1092	P07731092	SPANNER NUT
1093	P07731093	DRAWBAR 7/16-20 X 6-3/4
1094	P07731094	DRAWBAR CAP
1095	P07731095	MOTOR BLDC 230V W80-500WC
1096	P07731096	KEY 5 X 5 X 20
1097	P07731097	MOTOR PULLEY
1098	P07731098	FENDER WASHER 6MM
1099	P07731099	TIMING BELT HTD 350-SM
1100	P07731100	FLAT HD SCR M6-1 X 18
1101	P07731101	MOTOR MOUNTING PLATE
1102	P07731102	GEARBOX
1103	P07731103	SPINDLE BOX
1104	P07731104	SET SCREW M6-1 X 25 CONE-PT
1105	P07731105	GROUND INDICATOR PLATE
1106	P07731106	MILL BODY
1107	P07731107	MILL GIB
1108	P07731108	CAP SCREW M8-1.25 X 80
1113	P07731113	WORM GEAR
1114	P07731114	KEY 4 X 4 X 20
1115	P07731115	GEARED SHAFT 14T
1116	P07731116	GEAR 29T
1117	P07731117	WORM SUPPORT
1118	P07731118	DOWEL PIN 4 X 16
1119	P07731119	COMPRESSION SPRING
1120	P07731120	SET SCREW M6-1 X 8
1121	P07731121	STEEL BALL 5MM
1122	P07731122	HANDLE LEVER M8-1.25 X 10
1123	P07731123	HANDLE KNOB M8-1.25
1124	P07731124	EXT RETAINING RING 12MM
1125	P07731125	DOWN-FEED HANDLE HUB M8-1.25
1126	P07731126	CAP SCREW M5-.8 X 20
1127	P07731127	FINE DOWN-FEED CONTROL COVER
1128	P07731128	PHLP HD SCR M4-.7 X 6
1129	P07731129	FINE DOWN-FEED LINKAGE (WORMGEAR)
1130	P07731130	TAPER PIN 3 X 12
1131	P07731131	DOWEL PIN 3 X 12
1132	P07731132	FINE DOWN-FEED LINKAGE (MIDDLE)
1133	P07731133	FINE DOWN FEED LINKAGE (KNOB)
1134	P07731134	CAP SCREW M5-.8 X 25
1135	P07731135	FINE DOWN-FEED CONTROL BRACKET
1136	P07731136	GRADUATED COLLAR
1137	P07731137	SET SCREW M4-.7 X 12 DOG-PT
1138	P07731138	FINE DOWN-FEED KNOB
1140	P07731140	CAP SCREW M6-1 X 35
1141	P07731141	TAP SCREW M4 X 10
1142	P07731142	MILL CIRCUIT BOARD ZM3405



Mill Parts Cont.

REF	PART #	DESCRIPTION
1142-1	P07731142-1	MILL CIRCUIT BOARD XMT-COM
1143	P07731143	ELECTRICAL BOX COVER
1145	P07731145	VARIABLE-SPEED CIRCUIT BOARD X-1
1145-1	P07731145-1	VARIABLE-SPEED DIAL
1146	P07731146	POWER INDICATOR LIGHT
1147	P07731147	FAULT INDICATOR LIGHT
1148	P07731148	SWITCH BOX COVER
1149	P07731149	TAP SCREW M6 X 10
1150	P07731150	POWER SWITCH KEDU KJD17B 120V
1151	P07731151	FUSE ENCLOSURE
1152	P07731152	MILL MOUNTING BRACKET
1153	P07731153	CONNECTING ROD M14-2 X 20
1154	P07731154	HEX NUT M14-2
1155	P07731155	ADJUSTABLE FOOT M14-2
1156	P07731156	SWITCHBOX FACEPLATE
1157	P07731157	FLAT HD SCR M4-.7 X 16
1158	P07731158	STRAIN RELIEF TYPE-5
1159	P07731159	CONDUIT
1160	P07731160	SET SCREW M6-1 X 8 CONE-PT
1162	P07731162	COLUMN COVER
1164	P07731164	SAFETY SHIELD MOUNTING BRACKET

REF	PART #	DESCRIPTION
1165	P07731165	CAP SCREW M4-.7 X 20
1166	P07731166	HEX NUT M6-1
1167	P07731167	FLAT WASHER 6MM
1168	P07731168	LIMIT SWITCH MOUNTING PLATE
1169	P07731169	CAP SCREW M4-.7 X 12
1170	P07731170	MILL SAFETY SHIELD CAM
1171	P07731171	SET SCREW M4-.7 X 6
1172	P07731172	SAFETY SHIELD MOUNT
1173	P07731173	FLAT WASHER 5MM
1174	P07731174	THUMB SCREW M5-.8 X 20
1175	P07731175	MILL SAFETY SHIELD
1176	P07731176	MILL SAFETY SHIELD EXTENSION
1177	P07731177	BRACKET
1178	P07731178	LIMIT SWITCH KEDU QKS7 AC15 250V
1179	P07731179	CAP SCREW M4-.7 X 30
1180	P07731180	FLAT HD SCR M4-.7 X 10
1181	P07731181	MAGNET
1182	P07731182	SAFETY WINDOW LATCH
1183	P07731183	CAP SCREW M4-.7 X 16
1184	P07731184	STRAIN RELIEF M12-1.75 TYPE-3
1185	P07731185	DRO CONNECTOR



Labels & Cosmetics

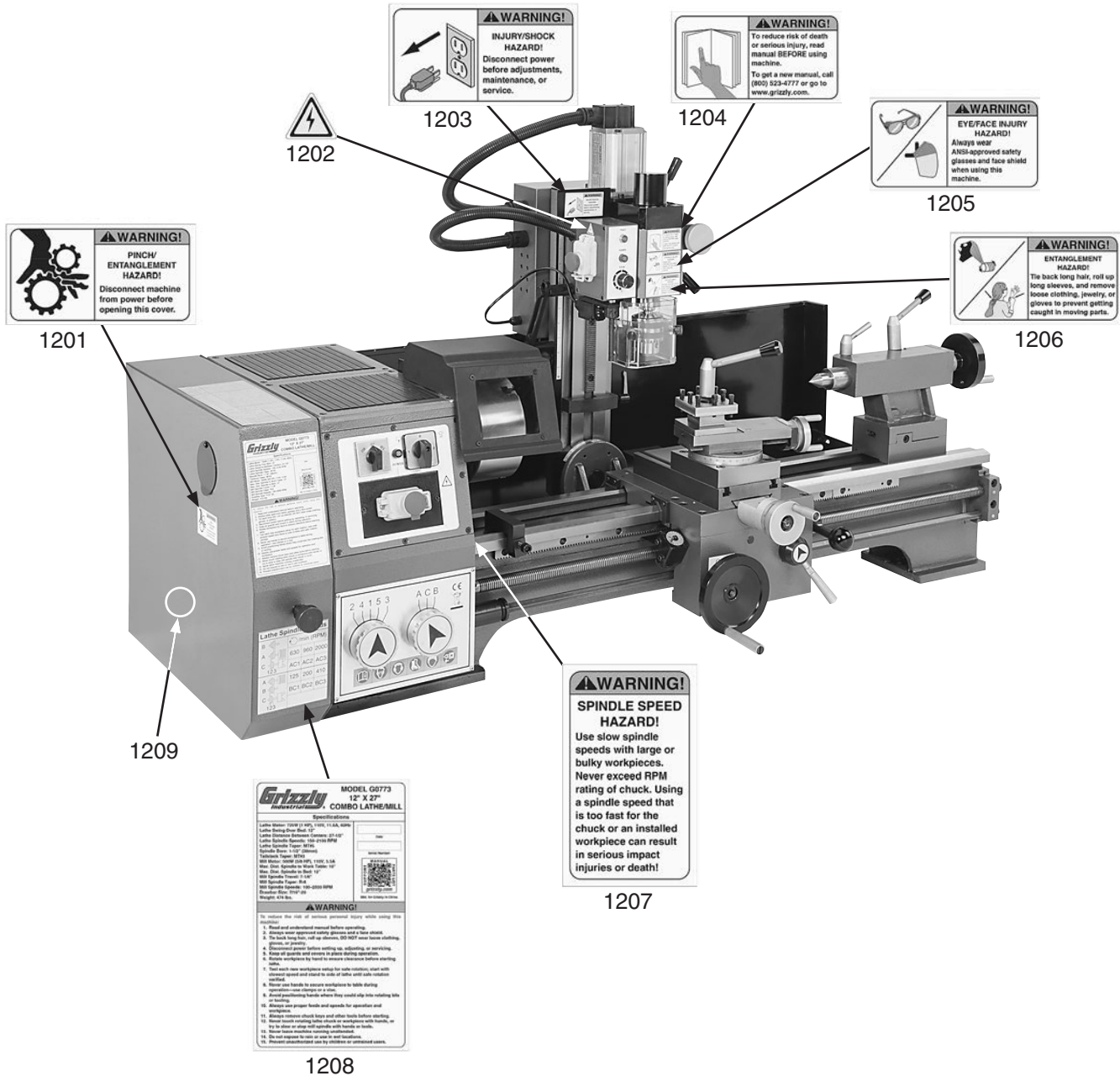

REF	PART #	DESCRIPTION
1201	P07731201	PINCH/ENTANGLEMENT LABEL
1202	P07731202	ELECTRICITY LABEL
1203	P07731203	DISCONNECT 110V LABEL
1204	P07731204	READ MANUAL LABEL
1205	P07731205	FACE SHIELD & SAFETY GLASSES LABEL

REF	PART #	DESCRIPTION
1206	P07731206	ENTANGLEMENT HAZARD LABEL
1207	P07731207	SPINDLE SPEED WARNING LABEL
1208	P07731208	MACHINE ID LABEL
1209	P07731209	GRIZZLY GREEN TOUCH-UP PAINT

⚠️ WARNING

Safety labels help reduce the risk of serious injury caused by machine hazards. If any label comes off or becomes unreadable, the owner of this machine **MUST** replace it in the original location before resuming operations. For replacements, contact (800) 523-4777 or www.grizzly.com.



SECTION 11: APPENDIX

Threading & Feeding Chart

Thread Dial Chart

Data Of Chasing Dial

	THREADS PER INCH						
	G	30			60		
	Lever	A	B	C	A	B	C
	1	72	36	18	36	18	9
	2	64	32	16	32	16	8
	3	56	28	14	28	14	7
	4	48	24	12	24	12	6
5	40	20	10	20	10	5	
	THREADS mm						
	G	30			35		
	Lever	A	B	C	A	B	C
	1						
	2		0.75	1.5			1.75
	3				0.5	1	2
	4	0.5	1	2			
	5	0.6			0.7		
	G	50			60		
	Lever	A	B	C	A	B	C
	1						
	2		1.25	2.5	0.75	1.5	3
	3						
4				1	2	4	
5	1	2	4				
THREADS PER INCH							
G	30						
Lever	A	B	C				
1			19				
G	30			30			
Lever	A	B	C	A	B	C	
1	0.0016	0.0032	0.0064	0.0008	0.0017	0.0034	
2	0.0018	0.0036	0.0072	0.0010	0.0019	0.0038	
3	0.0021	0.0041	0.0082	0.0011	0.0022	0.0043	
4	0.0024	0.0048	0.0096	0.0013	0.0025	0.0051	
5	0.0029	0.0058	0.0115	0.0015	0.0030	0.0061	

Thread Pitch	Using gear	Dial Shows
0.25	Z28 Or Z30	Random
0.5	Z28 Or Z30	Random
1	Z28 Or Z30	Random
1.25	Z30	0
2.5	Z30	0
0.3	Z28 Or Z30	Random
0.6	Z28 Or Z30	Random
1.5	Z28 Or Z30	Random
0.35	Z28	0
0.7	Z28	0
1.75	Z28	0
0.4	Z28 Or Z30	0
0.8	Z28	0
2	Z28 Or Z30	0





WARRANTY CARD

Name _____
 Street _____
 City _____ State _____ Zip _____
 Phone # _____ Email _____
 Model # _____ Order # _____ Serial # _____

The following information is given on a voluntary basis. It will be used for marketing purposes to help us develop better products and services. **Of course, all information is strictly confidential.**

1. How did you learn about us?

Advertisement Friend Catalog
 Card Deck Website Other:

2. Which of the following magazines do you subscribe to?

<input type="checkbox"/> Cabinetmaker & FDM	<input type="checkbox"/> Popular Science	<input type="checkbox"/> Wooden Boat
<input type="checkbox"/> Family Handyman	<input type="checkbox"/> Popular Woodworking	<input type="checkbox"/> Woodshop News
<input type="checkbox"/> Hand Loader	<input type="checkbox"/> Precision Shooter	<input type="checkbox"/> Woodsmith
<input type="checkbox"/> Handy	<input type="checkbox"/> Projects in Metal	<input type="checkbox"/> Woodwork
<input type="checkbox"/> Home Shop Machinist	<input type="checkbox"/> RC Modeler	<input type="checkbox"/> Woodworker West
<input type="checkbox"/> Journal of Light Cont.	<input type="checkbox"/> Rifle	<input type="checkbox"/> Woodworker's Journal
<input type="checkbox"/> Live Steam	<input type="checkbox"/> Shop Notes	<input type="checkbox"/> Other:
<input type="checkbox"/> Model Airplane News	<input type="checkbox"/> Shotgun News	
<input type="checkbox"/> Old House Journal	<input type="checkbox"/> Today's Homeowner	
<input type="checkbox"/> Popular Mechanics	<input type="checkbox"/> Wood	

3. What is your annual household income?

\$20,000-\$29,000 \$30,000-\$39,000 \$40,000-\$49,000
 \$50,000-\$59,000 \$60,000-\$69,000 \$70,000+

4. What is your age group?

20-29 30-39 40-49
 50-59 60-69 70+

5. How long have you been a woodworker/metalworker?

0-2 Years 2-8 Years 8-20 Years 20+ Years

6. How many of your machines or tools are Grizzly?

0-2 3-5 6-9 10+

7. Do you think your machine represents a good value? Yes No

8. Would you recommend Grizzly Industrial to a friend? Yes No

9. Would you allow us to use your name as a reference for Grizzly customers in your area?

Note: We never use names more than 3 times. Yes No

10. Comments: _____

CUT ALONG DOTTED LINE

FOLD ALONG DOTTED LINE

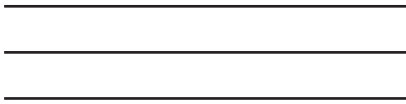

Place
Stamp
Here



GRIZZLY INDUSTRIAL, INC.
P.O. BOX 2069
BELLINGHAM, WA 98227-2069



FOLD ALONG DOTTED LINE

Send a Grizzly Catalog to a friend:

Name	_____
Street	_____
City	_____ State _____ Zip _____

TAPE ALONG EDGES--PLEASE DO NOT STAPLE

WARRANTY & RETURNS

Grizzly Industrial, Inc. warrants every product it sells for a period of **1 year** to the original purchaser from the date of purchase. This warranty does not apply to defects due directly or indirectly to misuse, abuse, negligence, accidents, repairs or alterations or lack of maintenance. This is Grizzly's sole written warranty and any and all warranties that may be implied by law, including any merchantability or fitness, for any particular purpose, are hereby limited to the duration of this written warranty. We do not warrant or represent that the merchandise complies with the provisions of any law or acts unless the manufacturer so warrants. In no event shall Grizzly's liability under this warranty exceed the purchase price paid for the product and any legal actions brought against Grizzly shall be tried in the State of Washington, County of Whatcom.

We shall in no event be liable for death, injuries to persons or property or for incidental, contingent, special, or consequential damages arising from the use of our products.

To take advantage of this warranty, contact us by mail or phone and give us all the details. We will then issue you a "Return Number," which must be clearly posted on the outside as well as the inside of the carton. We will not accept any item back without this number. Proof of purchase must accompany the merchandise.

The manufacturers reserve the right to change specifications at any time because they constantly strive to achieve better quality equipment. We make every effort to ensure that our products meet high quality and durability standards and we hope you never need to use this warranty.

Please feel free to write or call us if you have any questions about the machine or the manual.

Thank you again for your business and continued support. We hope to serve you again soon.

grizzly.com[®]
TOOL WEBSITE

Buy Direct and Save with Grizzly[®] – Trusted, Proven and a Great Value!
~Since 1983~

*Visit Our Website Today For
Current Specials!*

**ORDER
24 HOURS A DAY!
1-800-523-4777**

